



**1.0 RIDUTTORI - MOTORIDUTTORI PARALLELI - PENDOLARI
SHAFT GEARBOXES - SHAFT MOUNTED GEARBOXES
AND GEARED MOTORS
FLACH-UND AUFSTECKGETRIEBE UND-GETRIEBEMOTOREN**

**PM
PR, PC**

				Pag. Page Seite
1.1	Caratteristiche tecniche	<i>Technical characteristics</i>	Technische Eigenschaften	E2
1.2	Designazione	<i>Designation</i>	Bezeichnungen	E2
1.3	Versioni	<i>Versions</i>	Ausführungen	E5
1.4	Lubrificazione	<i>Lubrication</i>	Schmierung	E6
1.5	Carichi radiali e assiali	<i>Axial and overhung loads</i>	Radiale und Axiale Belastungen	E7
1.6	Prestazioni riduttori	<i>Gearboxes performances</i>	Leistungen der Getriebe	E8
1.7	Prestazioni motoriduttori	<i>Gearmotors performances</i>	Leistungen der Getriebemotoren	E13
1.8	Dimensioni	<i>Dimensions</i>	Abmessungen	E20
1.9	Accessori	<i>Accessories</i>	Zubehör	E33
1.10	Linguette	<i>Keys</i>	Paßfedern	E34





1.1 Caratteristiche tecniche

La progettazione di questi riduttori è stata impostata su una struttura monolitica particolarmente rigida che permette l'applicazione di elevati carichi.

I riduttori – motoriduttori paralleli o pendolari possono essere a 2 o 3 stadi.

1.1 Technical characteristics

The design of this series of gearboxes has been set up on a very rigid monolithic structure enabling the application of heavy loads.

1.1 Technische Eigenschaften

Der Entwicklung dieser Getriebeserie wurde eine monolithische Gehäusestruktur zugrunde gelegt.

Deren kompakte Bauweise sowie die besonders hohe Stabilität ermöglichen auch höchste Belastungen.

1.2 Designazione

1.2 Designation

1.2 Bezeichnung

	Versione Version Ausführung	Grand. Size Größe	Tipo Type Typ	*1	* 2	*3	*4	ir	IEC	Tipo Type Typ	Grand. Size Größe	Lunghezza Length Länge	Designazione Motori Designation Motors Bezeichnung Motoren	
													CT18IGBD1	
													Esempio / Example / Beispiel	
PM	P	63	—	—	—	—	—		80 (B5) 80 (B14)	PMP 63 1: 24.1 80 B5 PMF 63 1: 24.1 80 B5				
										F1	B C N	Diametro foro opzionale		Vedi tabelle prestazioni See performance tables Siehe Leistungstabellen
		F2	CD	O	PMF 71 - 1:14.0 - T 56 A 4 B5									
PR	F	90	—	—	—	—				PRP 90 P 1: 125.0 PRF 90 P 1: 125.0				
										P	FD FDB	S A		
PC		112	—	—	—	—				T TA ... H	56 ... 315	A ... ML	PMP 112 - 1:44.7 - T 56 A 4 B5	

P = Riduttori e motoriduttori paralleli / Parallel shaft gearboxes and motorgearboxes / Flachgetriebe und -Flachgetriebemotoren.
F = Riduttori e motoriduttori pendolari / Shaft mounted gearboxes and motorgearboxes / Aufsteckgetriebe und Aufsteckgetriebemotoren.

Specifiche:

Specification:

Spezifikationen:

- **[*1] Albero uscita:**
Nessuna indicazione = albero forato;
B = albero bisporgente integrale
C = albero forato con calettatore
N = Sporgente Integrale
D = Sporgente Scanalato
DB = Bisporgente integrale Scanalato
CD = Albero forato Scanalato
FD = Flangia brocciata
FDB = Flangia brocciata Bisporgente

- **[*1] Output shaft:**
No indication = shaft with keyway;
B = Double integral output shaft
C = hollow shaft with shrink disk
N = Output shaft
D = Splined output shaft
DB = Double splined shaft
CD = Splined hollow shaft
FD = Broached flange
FDB = Double broached flange

- **[*1] Abtriebswelle:**
Keine Angabe = Hohlwelle mit Paßfedernut
B = Doppeltem Integralwelle
C = Hohlwelle mit Schrumpfscheibe
N = Holwelle mit Wellenende
D = Abtriebswelle mit Keilende
DB = Doppelseitig verzahnte Welle
CD = Verzahnte Hohlwelle
FD = Geräumtem Flansch
FDB = Geraeumter Doppelflansch



1.2 Designazione

1.2 Designation

1.2 Bezeichnung

• [*2] Diametro albero:
Vedi tabella .

• [*2] Shaft diameter:
See table .

• [*2] Durchmesser Abtriebswelle:
S. Tabelle .

Grandezza Size Größe	[*3]										
	Albero forato Shaft with keyway Holwelle mit Paßfedernut	Albero forato con calettatore Hollow shaft with shrink disc Holwelle mit Schrumpfscheibe	Sporgente Integrale Output shaft Holwelle mit Wellenende	Bisorgente integrale Double output shaft Holwelle mit Doppeltem Wellenende	Sporgente Scanalato Splined output shaft Abtriebswelle mit Keilende	Sporgente Scanalato Splined hollow shaft Verzahnte Hohlwelle	Albero forato Scanalato Splined hollow shaft Verzahnte Hohlwelle	Flangia brocciata Broached flange Geräumtem Flansch	Flangia brocciata Bisorgente Double broached flange Geräumter Doppelflansch		
	Standard	Optional	Standard	Optional	Standard	Optional					
-	...	C	C...	N	B	D	DB	CD	FD	FDB	
63	∅ 30	∅ 25 ∅ 28	∅ 30	∅ 30 Standard		DIN 5482 28 x 25		DIN 5482 28 x 25	-		
71	∅ 35	∅ 30 ∅ 32	∅ 35	∅ 35 Standard		DIN 5482 35 x 31		DIN 5482 35 x 31	-		
90	∅ 40	∅ 42 ∅ 45 ∅ 48	∅ 40	∅ 40 Standard		DIN 5482 40 x 36		DIN 5482 40 x 36	-		
112	∅ 50	∅ 55	∅ 50	∅ 50 Standard		DIN 5482 50 x 45		DIN 5482 50 x 45	DIN 5482 50 x 45		

i Da verificare la compatibilità dimensionale con la versione richiesta/

• [*3] Posizione Albero:

Nessuna indicazione = lato destro (standard);
S = lato sinistro, montaggio dalla parte
opposta (opzionale).

• [*3] Mounting Shaft:

No indication (standard) = on right side;
S = on left side, on the opposite.

• [*3] Montageposition Welle:

Keine Angabe (Standard) = rechts;
S = links.

Albero forato con calettatore Hollow shaft with shrink disc Holwelle mit Schrumpfscheibe		S			-
Sporgente Integrale Output shaft Holwelle mit Wellenende		S			-
Sporgente Scanalato Splined output shaft Abtriebswelle mit Keilende		S			-
Albero forato Scanalato Splined hollow shaft Verzahnte Hohlwelle		S			-
Flangia brocciata Broached flange Geräumtem Flansch		S			-

**1.2 Designazione**

- [*4] **Senso di rotazione (valido solo se richiesto dispositivo antiretro):**

O = ORARIO (il riduttore può ruotare solo in senso orario visto dal lato destro come in figura)

A = ANTIORARIO.

1.2 Designation

- [*4] **Rotation sense (only necessary for solution with backstop device):**

O = CLOCKWISE (looking at the gearbox from the perspective shown below)

A = ANTICLOCKWISE.

1.2 Bezeichnung

- [*4] **Drehrichtung (Nur bei Ausführungen mit Rücklaufsperr)**

O = im Uhrzeigersinn (bei Betrachtung des Getriebes aus der unten dargestellten Perspektive)

A = Gegen den Uhrzeigersinn.

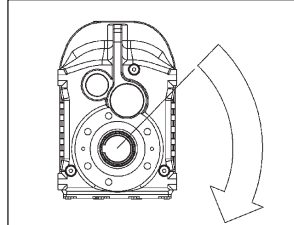

Altre specifiche:

- **[M1, M2, M3, M4, M5]** Posizioni di montaggio con indicazione dei tappi di livello, carico e scarico; se non specificato si considera standard la posizione **M6** (vedi par. 1.4).
- **[T]** Dispositivo antivibrante (solamente per versione PENDOLARE :vedi par. 1.9).
- **[2 o 3 o 4]** Posizione della morsettiera del motore se diversa da quella standard (1).

Further specification:

- **[M1, M2, M3, M4, M5]** Mounting position with indication of breather, level and drain plugs; if not specified, standard position is **M6** (see par. 1.4).
- **[T]** Rubber buffer (only for shaft mounted version see par. 1.9).
- **[2 o 3 o 4]** Position of the motor terminal box if different from the standard one [1] (for gearmotors)

Weitere Spezifikationen:

- Montageposition **[M1, M2, M3, M4, M5]** mit Angabe von Entlüftung, Schaugläsern und Ablasschraube. Wenn nicht näher spezifiziert, wird die Standardposition **M6** zugrunde gelegt (s. Abschnitt 1.4).
- **[T]** Gummihülse (nur bei Aufsteckausführung: s. par. 1.9).
- Montageposition Klemmenkasten **[2, 3, 4]**, wenn abweichend von Standardposition [1] (für Motorgetriebe).



Posizione morsettiera
Terminal board position
Lage des Klemmenkastens



P.P

P.F

P.P P - P. P F
P.F P - P. F F

PM. (IEC)
63 — 112

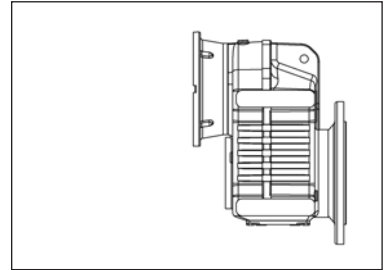
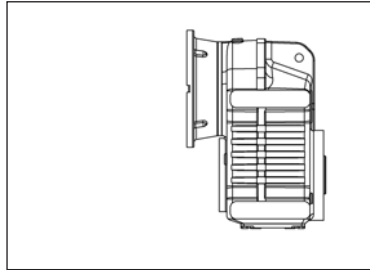
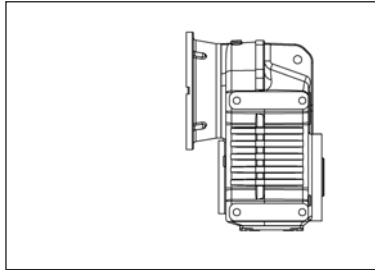

PM. (kW)
63 — 112

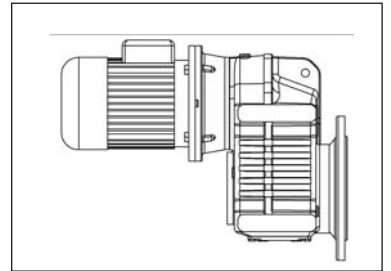
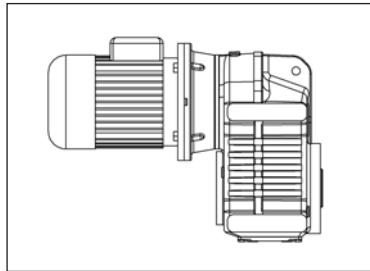
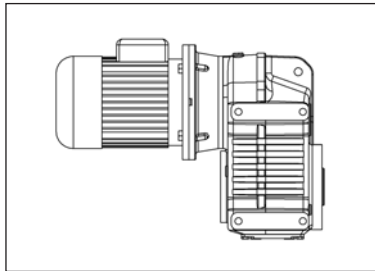

1- STANDARD

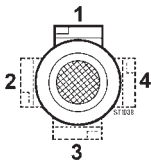

Posizione morsetteria
Terminal board position
Lage des Klemmenkastens

PR.
63 — 112

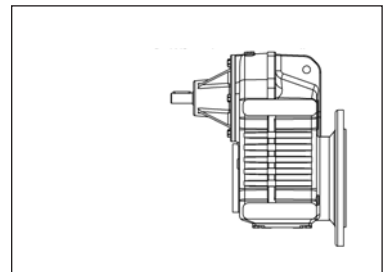
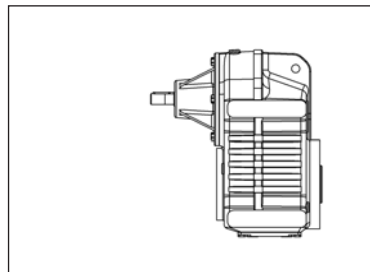
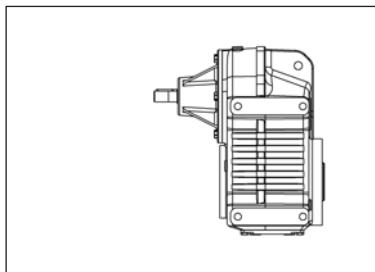

PC.
63 — 112

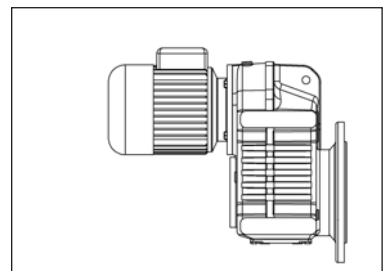
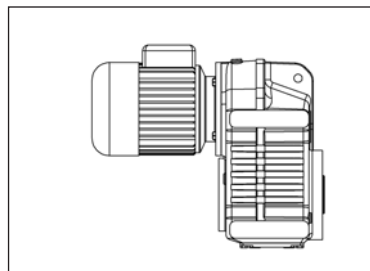
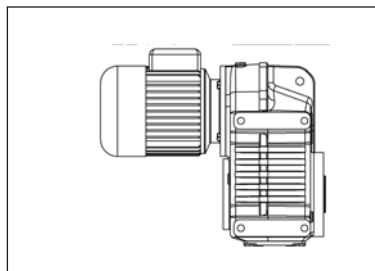

Senso di rotazione
Direction of rotation
Drehrichtung

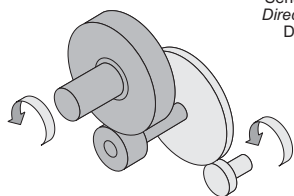

2 stadi/stages/stufig

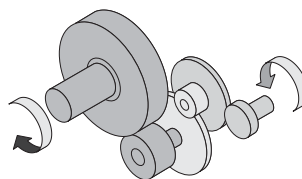

3 stadi/stages/stufig



1.4 Lubrificazione

Generalità

Si consiglia l'uso di oli a base sintetica. (Vedere a tale proposito le indicazioni riportate nel capitolo A, paragrafo 1.6). Nella Tab. 4.2 sono riportati i quantitativi di olio necessari per il corretto funzionamento dei riduttori.

Prescrizioni in fase d'ordine e stato di fornitura

I riduttori della grandezza 63, 71 è forniti completi di olio sintetico di viscosità ISO 320. Per questi riduttori è **necessario** specificare la posizione di montaggio.

I riduttori nelle grandezze 90, 112 sono forniti predisposti per lubrificazione ad olio ma privi di lubrificante il quale potrà essere fornito a richiesta.

Per questi riduttori è **necessario** specificare la posizione di montaggio.

1.4 Lubrication

General information

The use of synthetic oil is recommended (see details in Chapter A, paragraph 1.6). Tab. 4.2 shows the quantities of oil required for correct parallel-shaft mounted gearbox performance.

Ordering phase requirements and state of supply

Size 63, 71 gearbox is supplied with ISO 320 viscosity synthetic oil. **It is necessary** to specify mounting position of this gearbox.

Size 90 and 112 . parallel - shaft mounted gearboxes are supplied pre-arranged for oil lubrication but without lubricant that can be requested separately.

It is necessary to specify the mounting position with these gearboxes.

1.4 Schmierung

Allgemeines

Der Einsatz von synthetischem Öl wird empfohlen. (Siehe diesbezüglich die Hinweise im Kapitel A, Abschnitt 1.6).

In der Tab. 4.2 werden die erforderlichen Ölfüllmengen für einen störungsfreien Betrieb

Vorgaben für die Bestellung und den Lieferzustand

Die Getriebe in der Baugröße 63, 71 wird komplett mit Synthetiköl mit einer Viskosität ISO 320 geliefert.

Für dieses Getriebe **muss** die Einbaulage verbindlich angegeben werden.

Die Getriebe in den Baugrößen 90 und 112 sind bei der Lieferung für die Ölschmierung vorbereitet, enthalten jedoch kein Schmiermittel. Dieses kann auf Anfrage geliefert werden.

Für diese Getriebe **muss** die Einbaulage verbindlich angegeben werden.

Posizioni di montaggio

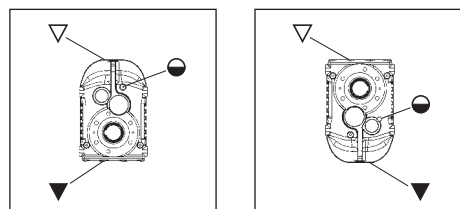

M1

M2

Mounting positions

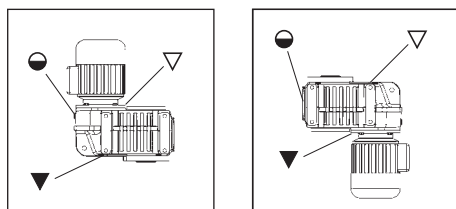

M3

M4

Montagepositionen

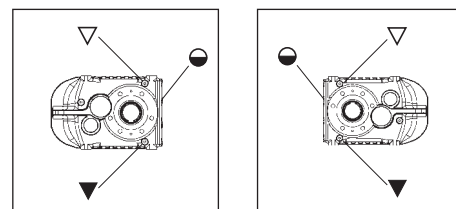

M5

M6

- ▽ Carico / Breather plug / Einfüll-u. Entlüftungsschraube
- Livello / Level plug / Schauglas
- ▼ Scarico / Drain plug / Ablassschraube



Tab. 4.2

Quantità di lubrificante / Lubricant Quantity / Schmiermittelmenge (kg)									
PM PR - PC	Posizioni di montaggio / Mounting Positions / Montagepositionen						Stato di fornitura State of supply Lieferzustand	* n°. tappi olio * No. of plugs Anzahl Betriebschraube	Posizione di montaggio Mounting position Montageposition
	M1	M2	M3	M4	M5	M6			
63	1.25	0.9	1.3	1.15	0.9	Riduttori forniti completi di olio sintetico Gearboxes supplied with synthetic oil Getriebe werden mit synthetischem Öl geliefert	1	Necessaria Necessary Erforderlich	
71	2.1	1.75	2.3	2.0	1.6		1		
90	3.3	2.8	3.8	3.7	2.65	Riduttori predisposti per lubrificazione ad olio Gearboxes supplied ready for oil lubrication Getriebe sind für Ölschmierung vorgesehen	6	Necessaria Necessary Erforderlich	
112	7.3	7.1	8.0	7.0	6.0		6		

ATTENZIONE

- A) Se in fase d'ordine la posizione di montaggio è omessa, il riduttore verrà fornito con i tappi predisposti per la posizione M1.
- B) Il tappo di sfiato è allegato solo nei riduttori che hanno più di un tappo olio.
- C) Eventuali forniture con predisposizioni tappi diverse da quella indicata in tabella, dovranno essere concordate.
- D) Nei riduttori dove è necessario specificare la posizione di montaggio, la posizione richiesta è indicata nella targhetta del riduttore.

WARNING

- A) It is necessary to specify the mounting position when ordering. If the mounting position is not specified in the ordering phase, the gearbox supplied will have plugs pre-arranged for position M1.
- B) A breather plug is supplied only with gearboxes that have more than one oil plug.
- C) The supply of gearboxes with different plug pre-arrangements has to be agreed with the manufacturer.
- D) The gearboxes that need a specific assembling position have the indication of it on the label of the gearbox.

ACHTUNG

- A) In der Auftragsphase muss die Einbaulage verbindlich angegeben werden. Sollte dies nicht erfolgen, wird das Getriebe mit Stopfen für die Einbaulage M1.
- B) Der Entlüftungstopfen ist lediglich bei den Getrieben vorhanden, die über mehr als einen Ölfüllstopfen verfügen.
- C) Lieferungen, die eine Auslegung hinsichtlich der Stopfen aufweisen, die von den Angaben in der Tabelle abweichen, müssen vorab vereinbart werden.
- D) In den Getrieben in dem man die Montage Position angeben soll, findet man die angefragte Position auf dem Typenschild des Getriebes.



1.5 Carichi radiali e assiali

Quando la trasmissione del moto avviene tramite meccanismi che generano carichi radiali sull'estremità dell'albero, è necessario verificare che i valori risultanti non eccedono quelli indicati nelle tabelle.

Nella Tab. 4.3 sono riportati i valori dei carichi radiali ammissibili per l'albero veloce (Fr_1). Come carico assiale ammissibile contemporaneo si ha:

$$Fa_1 = 0.2 \times Fr_1$$

In Tab. 4.4 sono riportati i valori dei carichi radiali ammissibili per l'albero lento (Fr_2). Come carico assiale ammissibile contemporaneo si ha:

$$Fa_2 = 0.2 \times Fr_2$$

Tab. 4.3

n_1 [min ⁻¹]	Fr_1 [N]							
	PR.							
	63/2	63/3	71/2	71/3	90/2	90/3	112/2	112/3
2800	200	550	600	600	600	1300	800	1400
1400	400	700	900	800	700	1500	1400	1800
900	400	800	1100	1000	800	1600	1500	2100
500	400	950	1300	1200	900	1800	1800	2600

Tab. 4.4

n_2 [min ⁻¹]	Fr_2 [N]			
	PM. - PR. - PC.			
	63	71	90	112
1100	—	3000	6500	—
950	1400	3050	7000	7600
775	1450	3100	7200	7900
625	1500	3230	7600	8300
500	1580	3340	7900	8800
400	1660	3450	8300	9200
320	1720	3550	8900	9800
260	1750	3600	9000	10400
200	1800	4100	9000	10800
160	1950	4300	9000	11400
125	2200	4600	9000	12000
90	2400	4900	9000	13000
60	2600	5000	9300	13800
40	2800	5000	10000	15300
25	3100	6000	11200	16500
16	3800	6600	11500	17000
10	4500	6600	11500	17400

I carichi radiali indicati nelle tabelle si intendono applicati a metà della sporgenza dell'albero lento standard (vedi fig. 8.14) e sono riferiti ai riduttori operanti con fattore di servizio 1. Valori intermedi relativi a velocità non riportate possono essere ottenuti per interpolazione considerando però che Fr_1 a 500 min⁻¹ e Fr_2 a 5 min⁻¹ rappresentano i carichi massimi consentiti. Per i carichi non agenti sulla mezzeria dell'albero lento o veloce si ha:

- a 0.3 della sporgenza:
 $Fr_x = 1.25 \times Fr_{1-2}$
- a 0.8 dalla sporgenza:
 $Fr_x = 0.8 \times Fr_{1-2}$

1.5 Axial and overhung load

Should transmission movement determine radial loads on the angular shaft end, it is necessary to make sure that resulting values do not exceed the ones indicated in the tables.

In Table 4.3 permissible radial load for input shaft are listed (Fr_1). Contemporary permissible axial load is given by the following formula:

$$Fa_1 = 0.2 \times Fr_1$$

In Table 4.4 permissible radial loads for output shaft are listed (Fr_2). Permissible axial load is given by the following formula:

$$Fa_2 = 0.2 \times Fr_2$$

1.5 Radiale und axiale Belastungen

Wird das Wellenende auch durch Radialkräfte belastet, so muß sichergestellt werden, daß die resultierenden Werte die in der Tabelle angegebenen nicht überschreiten.

In Tabelle 4.3 sind die Werte der zulässigen Radialbelastungen für die Antriebswelle (Fr_1) angegeben. Die Axialbelastung beträgt dann:

$$Fa_1 = 0.2 \times Fr_1$$

In Tabelle 4.4 sind die Werte der zulässigen Radialbelastungen für die Abtriebswelle (Fr_2) angegeben. Als zulässige Axialbelastung gilt:

$$Fa_2 = 0.2 \times Fr_2$$

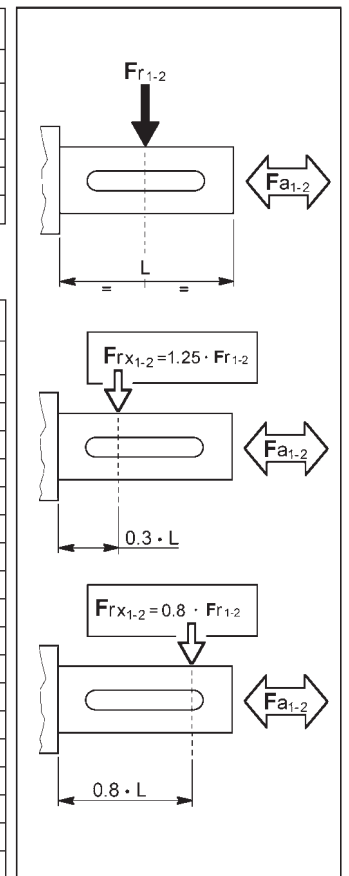

The radial loads shown in the tables are applied on the middle of standard shaft extensions (see fig.8.14). Base of these values is a service factor 1.

Values for speeds that are not listed can be obtained through interpolation but it must be considered that Fr_1 at 500 min⁻¹ and Fr_2 at 5 min⁻¹ represent the maximum allowable loads.

For radial loads which are not applied on the middle of the shafts, the following values can be calculated:

- at 0.3 from extension:
 $Fr_x = 1.25 \times Fr_{1-2}$
- at 0.8 from extension:
 $Fr_x = 0.8 \times Fr_{1-2}$

Bei den in der Tabelle angegebenen Radialbelastungen wird eine Kräfteinwirkung auf die Mitte der Standardwelle (s. A.8.14) angenommen; außerdem wird ein Betriebsfaktor 1 zugrunde gelegt. Zwischenwerte für nicht aufgeführte Drehzahlen können durch Interpolation ermittelt werden. Hierbei ist jedoch zu berücksichtigen, daß Fr_1 bei 500 min⁻¹ und für Fr_{2max} bei 5 min⁻¹ die maximal zulässigen Belastungen repräsentieren.

Ist die Einwirkung der Radialkraft nicht in der Mitte der Welle, so können die zulässigen Radiallasten folgendermaßen ermittelt werden:

- 0.3 vom Wellenabsatz entfernt:
 $Fr_x = 1.25 \times Fr_{1-2}$
- 0.8 vom Wellenabsatz entfernt:
 $Fr_x = 0.8 \times Fr_{1-2}$



PR 63/2



9.0

ir	$n_1 = 2800 \text{ min}^{-1}$				$n_1 = 1400 \text{ min}^{-1}$				$n_1 = 900 \text{ min}^{-1}$				$n_1 = 500 \text{ min}^{-1}$				IEC
	n_2	T_{2M}	P	RD	n_2	T_{2M}	P	RD	n_2	T_{2M}	P	RD	n_2	T_{2M}	P	RD	
	min^{-1}	Nm	kW	%	min^{-1}	Nm	kW	%	min^{-1}	Nm	kW	%	min^{-1}	Nm	kW	%	
3.0	935.6	77	7.9	95	467.8	80	4.1	95	300.7	85	2.8	95	167.1	88	1.6	95	112 B5 112 B14 100 B5 100 B14 90 B5 90 B14 80 B5 80 B14 71 B5 63 B5
3.9	719.9	90	7.1	95	360.0	110	4.4	95	231.4	115	2.9	95	128.6	120	1.7	95	
4.3	645.0	95	6.8	95	322.5	130	4.6	95	207.3	135	3.1	95	115.2	140	1.8	95	
5.0	557.0	110	6.8	95	278.5	140	4.3	95	179.0	150	3.0	95	99.5	155	1.7	95	
5.6	499.0	125	6.9	95	249.5	160	4.4	95	160.4	170	3.0	95	89.1	180	1.8	95	
6.2	452.2	130	6.5	95	226.1	160	4.0	95	145.3	175	2.8	95	80.7	180	1.6	95	
6.5	431.2	135	6.4	95	215.6	170	4.0	95	138.6	185	2.8	95	77.0	195	1.7	95	
7.4	379.1	140	5.9	95	189.6	180	3.8	95	121.9	190	2.6	95	67.7	200	1.5	95	
8.0	347.9	150	5.8	95	174.0	200	3.8	95	111.8	215	2.7	95	62.1	230	1.6	95	
9.0	311.7	165	5.7	95	155.9	210	3.6	95	100.2	230	2.5	95	55.7	250	1.5	95	
10.4	269.4	180	5.3	95	134.7	220	3.3	95	86.6	240	2.3	95	48.1	255	1.4	95	
11.8	236.9	190	5.0	95	118.4	235	3.1	95	76.1	255	2.1	95	42.3	255	1.2	95	
13.5	206.9	205	4.7	95	103.4	250	2.9	95	66.5	255	1.9	95	36.9	255	1.0	95	
14.4	194.8	190	4.1	95	97.4	220	2.4	95	62.5	230	1.6	95	34.8	240	0.9	95	
16.9	166.1	230	4.2	95	83.0	250	2.3	95	53.4	255	1.5	95	29.7	255	0.8	95	
19.8	141.3	230	3.6	95	70.7	250	1.9	95	45.4	255	1.3	95	25.2	255	0.7	95	
20.5	136.6	210	3.2	95	68.3	230	1.7	95	43.9	240	1.2	95	24.4	250	0.7	95	
24.1	116.2	210	2.7	95	58.1	230	1.5	95	37.3	245	1.0	95	20.7	250	0.6	95	
26.1	107.3	220	2.6	95	53.6	240	1.4	95	34.5	250	1.0	95	19.2	255	0.5	95	
31.7	88.2	220	2.1	95	44.1	240	1.2	95	28.4	250	0.8	95	15.8	250	0.4	95	
36.6	76.6	225	1.9	95	38.3	250	1.1	95	24.6	250	0.7	95	13.7	250	0.4	95	

PR 63/3



9.0

ir	$n_1 = 2800 \text{ min}^{-1}$				$n_1 = 1400 \text{ min}^{-1}$				$n_1 = 900 \text{ min}^{-1}$				$n_1 = 500 \text{ min}^{-1}$				IEC
	n_2	T_{2M}	P	RD	n_2	T_{2M}	P	RD	n_2	T_{2M}	P	RD	n_2	T_{2M}	P	RD	
	min^{-1}	Nm	kW	%	min^{-1}	Nm	kW	%	min^{-1}	Nm	kW	%	min^{-1}	Nm	kW	%	
43.4	64.6	220	1.6	93	32.3	250	0.9	93	20.7	250	0.6	93	11.5	250	0.3	93	80 B5 80 B14 71 B5 63 B5
47.0	59.6	200	1.3	93	29.8	250	0.8	93	19.2	255	0.6	93	10.6	255	0.3	93	
53.3	52.5	220	1.3	93	26.3	250	0.7	93	16.9	255	0.5	93	9.4	255	0.3	93	
57.2	48.9	230	1.3	93	24.5	250	0.7	93	15.7	255	0.5	93	8.7	255	0.3	93	
61.8	45.3	230	1.2	93	22.7	250	0.6	93	14.6	255	0.4	93	8.1	255	0.2	93	
69.6	40.2	240	1.1	93	20.1	250	0.6	93	12.9	250	0.4	93	7.2	250	0.2	93	
75.4	37.1	240	1.0	93	18.6	250	0.5	93	11.9	255	0.3	93	6.6	255	0.2	93	
81.4	34.4	240	0.9	93	17.2	250	0.5	93	11.1	255	0.3	93	6.1	255	0.2	93	
88.4	31.7	240	0.9	93	15.8	250	0.4	93	10.2	250	0.3	93	5.7	250	0.2	93	
98.9	28.3	240	0.8	93	14.2	250	0.4	93	9.1	250	0.3	93	5.1	250	0.1	93	
114.4	24.5	240	0.7	93	12.2	250	0.3	93	7.9	255	0.2	93	4.4	260	0.1	93	
135.4	20.7	240	0.6	93	10.3	250	0.3	93	6.6	255	0.2	93	3.7	260	0.1	93	
149.1	18.8	240	0.5	93	9.4	250	0.3	93	6.0	255	0.2	93	3.4	260	0.1	93	
164.7	17.0	240	0.5	93	8.5	250	0.2	93	5.5	250	0.2	93	3.0	260	0.1	93	
181.3	15.4	240	0.4	93	7.7	250	0.2	93	5.0	250	0.1	93	2.8	260	0.1	93	
216.9	12.9	240	0.3	93	6.5	250	0.2	93	4.2	255	0.1	93	2.3	260	0.1	93	



PR 71/2



14.0

ir	n ₁ = 2800 min ⁻¹				n ₁ = 1400 min ⁻¹				n ₁ = 900 min ⁻¹				n ₁ = 500 min ⁻¹				IEC
	n ₂ min ⁻¹	T _{2M} Nm	P kW	RD %	n ₂ min ⁻¹	T _{2M} Nm	P kW	RD %	n ₂ min ⁻¹	T _{2M} Nm	P kW	RD %	n ₂ min ⁻¹	T _{2M} Nm	P kW	RD %	
2.6	1078.5	120	14.3	95	539.3	130	7.7	95	346.7	130	5.0	95	192.6	130	2.8	95	112 B5 112 B14 100 B5 100 B14 90 B5 90 B14 80 B5 80 B14 71 B5
3.2	880.4	140	13.6	95	440.2	150	7.3	95	283.0	150	4.7	95	157.2	150	2.6	95	
3.8	745.8	160	13.2	95	372.9	175	7.2	95	239.7	180	4.8	95	133.2	180	2.6	95	
4.3	650.3	180	12.9	95	325.2	200	7.2	95	209.0	210	4.8	95	116.1	210	2.7	95	
5.3	530.9	180	10.5	95	265.4	210	6.1	95	170.6	230	4.3	95	94.8	230	2.4	95	
6.2	449.7	230	11.4	95	224.8	260	6.4	95	144.5	300	4.8	95	80.3	300	2.7	95	
7.1	395.3	270	11.8	95	197.6	300	6.5	95	127.1	330	4.6	95	70.6	330	2.6	95	
8.7	322.7	280	10.0	95	161.3	310	5.5	95	103.7	350	4.0	95	57.6	350	2.2	95	
10.2	273.3	370	11.1	95	136.7	420	6.3	95	87.9	470	4.6	95	48.8	470	2.5	95	
11.6	242.0	380	10.1	95	121.0	430	5.7	95	77.8	480	4.1	95	43.2	480	2.3	95	
12.3	228.2	280	7.0	95	114.1	300	3.8	95	73.3	310	2.5	95	40.7	310	1.4	95	
14.0	199.5	400	8.8	95	99.8	450	4.9	95	64.1	480	3.4	95	35.6	480	1.9	95	
16.1	173.9	420	8.0	95	86.9	460	4.4	95	55.9	480	3.0	95	31.0	480	1.6	95	
17.3	161.7	420	7.5	95	80.9	460	4.1	95	52.0	480	2.8	95	28.9	480	1.5	95	
18.7	150.0	420	6.9	95	75.0	460	3.8	95	48.2	480	2.6	95	26.8	480	1.4	95	
20.2	138.7	420	6.4	95	69.3	460	3.5	95	44.6	480	2.4	95	24.8	480	1.3	95	
21.9	127.8	420	5.9	95	63.9	460	3.2	95	41.1	480	2.2	95	22.8	480	1.2	95	
25.3	110.9	360	4.4	95	55.4	410	2.5	95	35.6	410	1.6	95	19.8	410	0.9	95	
28.8	97.2	410	4.4	95	48.6	460	2.5	95	31.2	460	1.6	95	17.4	460	0.9	95	
33.1	84.7	370	3.5	95	42.4	410	1.9	95	27.2	410	1.2	95	15.1	410	0.7	95	
37.3	75.1	365	3.0	95	37.5	410	1.7	95	24.1	410	1.1	95	13.4	420	0.6	95	
44.7	62.6	400	2.8	95	31.3	460	1.6	95	20.1	460	1.0	95	11.2	480	0.6	95	
50.5	55.5	400	2.4	95	27.7	460	1.4	95	17.8	460	0.9	95	9.9	480	0.5	95	

PR 71/3



14.0

ir	n ₁ = 2800 min ⁻¹				n ₁ = 1400 min ⁻¹				n ₁ = 900 min ⁻¹				n ₁ = 500 min ⁻¹				IEC
	n ₂ min ⁻¹	T _{2M} Nm	P kW	RD %	n ₂ min ⁻¹	T _{2M} Nm	P kW	RD %	n ₂ min ⁻¹	T _{2M} Nm	P kW	RD %	n ₂ min ⁻¹	T _{2M} Nm	P kW	RD %	
39.5	70.8	420	3.3	93	35.4	460	1.8	93	22.8	470	1.2	93	12.6	480	0.7	93	90 B5 90 B14 80 B5 80 B14 71 B5 63 B5
53.5	52.3	420	2.5	93	26.2	460	1.4	93	16.8	460	0.9	93	9.3	480	0.5	93	
60.8	46.0	420	2.2	93	23.0	460	1.2	93	14.8	460	0.8	93	8.2	480	0.4	93	
64.2	43.6	420	2.1	93	21.8	460	1.1	93	14.0	470	0.7	93	7.8	480	0.4	93	
75.4	37.2	420	1.8	93	18.6	460	1.0	93	11.9	470	0.6	93	6.6	480	0.4	93	
86.8	32.3	420	1.5	93	16.1	460	0.8	93	10.4	470	0.5	93	5.8	480	0.3	93	
91.5	30.6	420	1.4	93	15.3	460	0.8	93	9.8	470	0.5	93	5.5	480	0.3	93	
99.3	28.2	420	1.3	93	14.1	460	0.7	93	9.1	470	0.5	93	5.0	480	0.3	93	
107.5	26.0	420	1.2	93	13.0	460	0.7	93	8.4	470	0.4	93	4.6	480	0.3	93	
123.8	22.6	420	1.1	93	11.3	460	0.6	93	7.3	480	0.4	93	4.0	520	0.2	93	
134.3	20.9	420	1.0	93	10.4	460	0.5	93	6.7	490	0.4	93	3.7	520	0.2	93	
154.8	18.1	420	0.9	93	9.0	460	0.5	93	5.8	500	0.3	93	3.2	520	0.2	93	
163.2	17.2	420	0.8	93	8.6	460	0.4	93	5.5	470	0.3	93	3.1	480	0.2	93	
191.6	14.6	450	0.7	93	7.3	490	0.4	93	4.7	520	0.3	93	2.6	540	0.2	93	
220.8	12.7	450	0.6	93	6.3	500	0.4	93	4.1	520	0.2	93	2.3	540	0.1	93	



PR 90/2



30

ir	$n_1 = 2800 \text{ min}^{-1}$				$n_1 = 1400 \text{ min}^{-1}$				$n_1 = 900 \text{ min}^{-1}$				$n_1 = 500 \text{ min}^{-1}$				IEC
	n_2 min^{-1}	T_{2M} Nm	P kW	RD %	n_2 min^{-1}	T_{2M} Nm	P kW	RD %	n_2 min^{-1}	T_{2M} Nm	P kW	RD %	n_2 min^{-1}	T_{2M} Nm	P kW	RD %	
2.7	1025.6	270	30.5	95	512.8	330	18.7	95	329.7	330	12.0	95	183.2	330	6.7	95	132 B5 132 B14
4.2	662.1	390	28.5	95	331.0	480	17.5	95	212.8	480	11.3	95	118.2	480	6.3	95	
5.3	528.9	430	25.1	95	264.5	530	15.4	95	170.0	530	9.9	95	94.5	530	5.5	95	
5.9	470.7	450	23.3	95	235.3	560	14.5	95	151.3	560	9.3	95	84.1	560	5.2	95	
6.7	417.1	480	22.1	95	208.6	600	13.8	95	134.1	600	8.9	95	74.5	600	4.9	95	
7.8	361.0	520	20.7	95	180.5	650	12.9	95	116.0	700	9.0	95	64.5	720	5.1	95	
8.7	321.8	460	16.3	95	160.9	560	9.9	95	103.4	560	6.4	95	57.5	560	3.5	95	
9.3	300.2	460	15.2	95	150.1	560	9.3	95	96.5	560	6.0	95	53.6	560	3.3	95	
9.7	288.4	660	21.0	95	144.2	820	13.0	95	92.7	880	9.0	95	51.5	900	5.1	95	
10.9	256.7	700	19.8	95	128.3	860	12.2	95	82.5	920	8.4	95	45.8	920	4.6	95	
12.3	227.4	740	18.6	95	113.7	910	11.4	95	73.1	920	7.4	95	40.6	940	4.2	95	
14.0	200.5	740	16.4	95	100.2	910	10.1	95	64.4	920	6.5	95	35.8	940	3.7	95	
16.0	175.5	740	14.3	95	87.7	910	8.8	95	56.4	920	5.7	95	31.3	940	3.2	95	
17.1	163.7	740	13.4	95	81.8	910	8.2	95	52.6	920	5.3	95	29.2	940	3.0	95	
19.8	141.3	740	11.5	95	70.7	910	7.1	95	45.4	920	4.6	95	25.2	940	2.6	95	
21.4	130.7	740	10.7	95	65.4	910	6.6	95	42.0	920	4.3	95	23.3	940	2.4	95	
25.0	112.2	740	9.1	95	56.1	910	5.6	95	36.1	920	3.7	95	20.0	940	2.1	95	
27.7	101.0	740	8.2	95	50.5	910	5.1	95	32.5	920	3.3	95	18.0	940	1.9	95	
30.5	91.7	740	7.5	95	45.9	910	4.6	95	29.5	920	3.0	95	16.4	940	1.7	95	
35.0	80.0	700	6.2	95	40.0	850	3.7	95	25.7	890	2.5	95	14.3	920	1.4	95	
40.4	69.3	585	4.5	95	34.7	720	2.8	95	22.3	760	1.9	95	12.4	820	1.1	95	
44.1	63.5	700	4.9	95	31.8	860	3.0	95	20.4	950	2.1	95	11.3	1000	1.4	95	
50.9	55.0	700	4.2	95	27.5	860	2.6	95	17.7	950	1.9	95	9.8	1000	1.1	95	

PR 90/3



30

ir	$n_1 = 2800 \text{ min}^{-1}$				$n_1 = 1400 \text{ min}^{-1}$				$n_1 = 900 \text{ min}^{-1}$				$n_1 = 500 \text{ min}^{-1}$				IEC
	n_2 min^{-1}	T_{2M} Nm	P kW	RD %	n_2 min^{-1}	T_{2M} Nm	P kW	RD %	n_2 min^{-1}	T_{2M} Nm	P kW	RD %	n_2 min^{-1}	T_{2M} Nm	P kW	RD %	
38.7	72.3	700	5.7	93	36.2	910	3.7	93	23.2	945	2.5	93	12.9	945	1.4	93	100 B5 100 B14
43.7	64.0	750	5.4	93	32.0	910	3.3	93	20.6	945	2.2	93	11.4	945	1.2	93	
48.8	57.4	750	4.8	93	28.7	910	2.9	93	18.4	945	2.0	93	10.2	945	1.1	93	
55.2	50.7	720	4.1	93	25.4	910	2.6	93	16.3	945	1.7	93	9.1	945	1.0	93	
62.3	44.9	750	3.8	93	22.5	910	2.3	93	14.4	945	1.5	93	8.0	945	0.9	93	
70.6	39.7	800	3.6	93	19.8	910	2.0	93	12.8	945	1.4	93	7.1	945	0.8	93	
76.3	36.7	800	3.3	93	18.3	910	1.9	93	11.8	945	1.3	93	6.6	945	0.7	93	
82.8	33.8	800	3.0	93	16.9	910	1.7	93	10.9	945	1.2	93	6.0	945	0.6	93	
93.3	30.0	800	2.7	93	15.0	910	1.5	93	9.6	945	1.0	93	5.4	945	0.6	93	
100.6	27.8	800	2.5	93	13.9	910	1.4	93	8.9	945	1.0	93	5.0	945	0.5	93	
108.9	25.7	910	2.6	93	12.9	910	1.3	93	8.3	945	0.9	93	4.6	945	0.5	93	
125.0	22.4	910	2.3	93	11.2	910	1.1	93	7.2	945	0.8	93	4.0	945	0.4	93	
141.0	19.9	910	2.0	93	9.9	910	1.0	93	6.4	945	0.7	93	3.5	945	0.4	93	
155.2	18.0	910	1.8	93	9.0	910	0.9	93	5.8	945	0.6	93	3.2	945	0.3	93	
178.1	15.7	910	1.6	93	7.9	910	0.8	93	5.1	945	0.5	93	2.8	945	0.3	93	
201.0	13.9	910	1.4	93	7.0	910	0.7	93	4.5	945	0.5	93	2.5	945	0.3	93	
224.4	12.5	910	1.3	93	6.2	910	0.6	93	4.0	945	0.4	93	2.2	945	0.2	93	
253.2	11.1	910	1.1	93	5.5	910	0.6	93	3.6	945	0.4	93	2.0	945	0.2	93	



1.6 Prestazioni riduttori PR

1.6 PR gearboxes performances

1.6 Leistungen der PR-Getriebe

PR 112/2



59

ir	n ₁ = 2800 min ⁻¹				n ₁ = 1400 min ⁻¹				n ₁ = 900 min ⁻¹				n ₁ = 500 min ⁻¹				IEC
	n ₂ min ⁻¹	T _{2M} Nm	P kW	RD %	n ₂ min ⁻¹	T _{2M} Nm	P kW	RD %	n ₂ min ⁻¹	T _{2M} Nm	P kW	RD %	n ₂ min ⁻¹	T _{2M} Nm	P kW	RD %	
2.9	967.0	480	51.2	95	483.5	600	32.0	95	310.8	650	22.3	95	172.7	650	12.4	95	160 B5 132 B5 112 B5 100 B5
3.4	831.9	520	47.7	95	416.0	640	29.3	95	267.4	690	20.3	95	148.6	700	11.5	95	
4.0	706.4	610	47.5	95	353.2	750	29.2	95	227.0	850	21.3	95	126.1	900	12.5	95	
4.6	607.7	660	44.2	95	303.8	820	27.5	95	195.3	920	19.8	95	108.5	960	11.5	95	
6.1	459.6	770	39.0	95	229.8	950	24.1	95	147.7	970	15.8	95	82.1	970	8.8	95	
6.8	412.4	810	36.8	95	206.2	990	22.5	95	132.5	1000	14.6	95	73.6	1000	8.1	95	
7.9	353.7	850	33.1	95	176.8	1050	20.5	95	113.7	1100	13.8	95	63.2	1100	7.7	95	
8.9	313.2	890	30.7	95	156.6	1100	19.0	95	100.7	1100	12.2	95	55.9	1100	6.8	95	
9.7	289.2	900	28.7	95	144.6	1100	17.5	95	93.0	1100	11.3	95	51.6	1100	6.3	95	
11.1	253.3	950	26.5	95	126.7	1100	15.4	95	81.4	1100	9.9	95	45.2	1100	5.5	95	
12.4	225.7	1150	28.6	95	112.8	1420	17.7	95	72.5	1600	12.8	95	40.3	1700	7.6	95	
14.5	193.6	1250	26.7	95	96.8	1550	16.5	95	62.2	1700	11.7	95	34.6	1850	7.0	95	
16.3	171.4	1320	24.9	95	85.7	1630	15.4	95	55.1	1800	10.9	95	30.6	1850	6.2	95	
17.7	158.3	1380	24.1	95	79.1	1700	14.8	95	50.9	1800	10.1	95	28.3	1850	5.8	95	
20.2	138.6	1440	22.0	95	69.3	1750	13.4	95	44.6	1850	9.1	95	24.8	1850	5.0	95	
21.7	129.3	1460	20.8	95	64.6	1750	12.5	95	41.6	1850	8.5	95	23.1	1850	4.7	95	
25.4	110.1	1460	17.7	95	55.1	1620	9.8	95	35.4	1720	6.7	95	19.7	1830	4.0	95	
29.1	96.1	1460	15.5	95	48.0	1750	9.3	95	30.9	1850	6.3	95	17.2	1850	3.5	95	
32.3	86.6	1460	13.9	95	43.3	1750	8.4	95	27.8	1850	5.7	95	15.5	1850	3.2	95	
38.9	72.0	1460	11.6	95	36.0	1750	6.9	95	23.1	1850	4.7	95	12.9	1850	2.6	95	
40.7	68.8	1460	11.1	95	34.4	1750	6.6	95	22.1	1800	4.4	95	12.3	1850	2.5	95	
44.7	62.6	1460	10.1	95	31.3	1750	6.0	95	20.1	1800	4.0	95	11.2	1900	2.3	95	
48.9	57.2	1460	9.2	95	28.6	1750	5.5	95	18.4	1850	3.7	95	10.2	1900	2.1	95	

PR 112/3



59

ir	n ₁ = 2800 min ⁻¹				n ₁ = 1400 min ⁻¹				n ₁ = 900 min ⁻¹				n ₁ = 500 min ⁻¹				IEC
	n ₂ min ⁻¹	T _{2M} Nm	P kW	RD %	n ₂ min ⁻¹	T _{2M} Nm	P kW	RD %	n ₂ min ⁻¹	T _{2M} Nm	P kW	RD %	n ₂ min ⁻¹	T _{2M} Nm	P kW	RD %	
51.2	54.7	1350	8.3	93	27.4	1700	5.2	93	17.6	1860	3.7	93	9.8	1860	2.0	93	112 B5 100 B5 90 B5 80 B5
58.5	47.9	1400	7.5	93	23.9	1750	4.7	93	15.4	1860	3.2	93	8.6	1860	1.8	93	
62.7	44.7	1420	7.1	93	22.3	1750	4.4	93	14.4	1860	3.0	93	8.0	1860	1.7	93	
67.4	41.6	1440	6.7	93	20.8	1750	4.1	93	13.4	1860	2.8	93	7.4	1860	1.6	93	
72.6	38.6	1500	6.5	93	19.3	1750	3.8	93	12.4	1860	2.6	93	6.9	1860	1.4	93	
78.5	35.7	1500	6.0	93	17.8	1750	3.5	93	11.5	1860	2.4	93	6.4	1860	1.3	93	
87.3	32.1	1500	5.4	93	16.0	1750	3.2	93	10.3	1860	2.2	93	5.7	1860	1.2	93	
93.6	29.9	1500	5.1	93	15.0	1750	2.9	93	9.6	1860	2.0	93	5.3	1860	1.1	93	
108.4	25.8	1500	4.4	93	12.9	1750	2.5	93	8.3	1860	1.7	93	4.6	1860	1.0	93	
117.2	23.9	1500	4.0	93	11.9	1750	2.4	93	7.7	1860	1.6	93	4.3	1860	0.9	93	
128.3	21.8	1500	3.7	93	10.9	1750	2.2	93	7.0	1860	1.5	93	3.9	1860	0.8	93	
148.0	18.9	1500	3.2	93	9.5	1750	1.9	93	6.1	1860	1.3	93	3.4	1860	0.7	93	
167.0	16.8	1500	2.8	93	8.4	1750	1.7	93	5.4	1860	1.1	93	3.0	1860	0.6	93	
191.5	14.6	1500	2.5	93	7.3	1750	1.4	93	4.7	1860	1.0	93	2.6	1860	0.5	93	
220.9	12.7	1500	2.1	93	6.3	1750	1.2	93	4.1	1860	0.9	93	2.3	1860	0.5	93	
241.0	11.6	1500	2.0	93	5.8	1750	1.1	93	3.7	1900	0.8	93	2.1	1900	0.4	93	
278.1	10.1	1500	1.7	93	5.0	1750	1.0	93	3.2	1900	0.7	93	1.8	1900	0.4	93	

N.B.
Per i riduttori evidenziati dal doppio bordo nella colonna delle potenze è necessario verificare lo scambio termico del riduttore (come indicato nel par. A-1.5). Per maggiori informazioni contattare l'ufficio tecnico STM.

NOTE.
Pay attention please to the frame around the input power value: for this gearboxes it's important to check the thermal capacity (comp. par. A-1.5). For details please contact our technical office.

HINWEIS.
Sind in den Tabellen Nennleistungen eingerahmt, so ist die thermische Leistungsgrenze der Getriebe zu beachten (s. par. A-1.5). Für weitere Informationen wenden Sie sich bitte an unser technisches Büro.

N.B.
I pesi riportati sono indicativi e possono variare in funzione della versione del riduttore.

NOTE.
Listed weights are for reference only and can vary according to the gearbox version.

HINWEIS.
Die angegebenen Gewichtsmaße sind Richtwerte und können je nach Getriebeversion variieren.



Nella tab. 4.5 sono riportate le grandezze motore accoppiabili (IEC) unitamente alle dimensioni albero/flangia motore standard.

In table 4.5 the possible shaft/flange dimensions IEC standard are listed

In Tabelle 4.5 sind die verfügbaren IEC-Standardmotoreingänge mit den Wellen-u. Flanschabmessungen aufgelistet.

Tab. 4.5

Possibili accoppiamenti con motori IEC - Possible couplings with IEC motors - Mögliche Verbindungen mit IEC-Motoren			
	IEC	ir	
		Tutti / All / Alle	
PMP 63/2 PMF 63/2	63	11/140 (B5)	
	71	14/160 (B5)	
	80	19/200 (B5) - 19/120 (B14)	19/160 - 19/140
	90	24/200 (B5) - 24/140 (B14)	24/160 - 24/120
	100 112	28/250 (B5) - 28/160 (B14)	
PMP 63/3 PMF 63/3	63	11/140 (B5)	
	71	14/160 (B5)	
	80	19/200 (B5) - 19/120 (B14)	19/160 - 19/140
PMP 71/2 PMF 71/2	71	14/160 (B5)	14/200 - 14/140 - 14/120
	80	19/200 (B5) - 19/120 (B14)	19/160 - 19/140
	90	24/200 (B5) - 24/140 (B14)	24/160 - 24/120
	100 112	28/250 (B5) - 28/160 (B14)	
PMP 71/3 PMF 71/3	63	11/140 (B5)	
	71	14/160 (B5)	14/200 - 14/140 - 14/120
	80	19/200 (B5) - 19/120 (B14)	19/160 - 19/140
	90	24/200 (B5) - 24/140 (B14)	24/160 - 24/120

Possibili accoppiamenti con motori IEC - Possible couplings with IEC motors - Mögliche Verbindungen mit IEC-Motoren			
	IEC	ir	
		Tutti / All / Alle	
PMP 90/2 PMF 90/2	90	24/200 (B5)	24/300 - 24/250
	100 112	28/250 (B5)	28/200 - 28/300
	132	38/300 (B5) - 38/200 (B14)	38/250
PMP 90/3 PMF 90/3	71	14/160 (B5)	14/200-14/140-14/120
	80	19/200 (B5) - 19/120 (B14)	19/160 - 19/140
	90	24/200 (B5) - 24/140 (B14)	24/160 - 24/120
	100	28/250 (B5) - 28/160 (B14)	
PMP 112/2 PMF 112/2	100 112	28/250 (B5)	28/350 - 28/300
	132	38/300 (B5)	38/350 - 38/250
	160	42/350 (B5)	42/300 - 42/250
PMP 112/3 PMF 112/3	80	19/200 (B5)	
	90	24/200 (B5)	
	100 112	28/250 (B5)	

Legenda:

19/200 (B5) 19/160

19/200 : combinazione albero/flangia standard
(B5) : forma costruttiva motore IEC
19/160 : combinazioni albero/flangia a richiesta

Key:

19/200 (B5) 19/160

19/200 : standard shaft/flange combination
(B5) : IEC motor constructive shape
19/160 : shaft/flange combinations upon request

Legende:

19/200 (B5) 19/160

19/200 : Standardkombinationen Welle/Flansch
(B5) : Konstruktionsform IEC-Motor
19/160 : Sonderkombinationen Welle/Flansch



1.7 Prestazioni motoriduttori
PMP - PCP - PMF - PCF

n_2 min ⁻¹	ir	T2 Nm	FS'	PMP - PCP PMF - PCF	
----------------------------	----	----------	-----	------------------------	---

0.09 kW	$n_1 = 860 \text{ min}^{-1}$	63B 6
----------------	------------------------------	-------

64	13.5	13	19.9	63/2	63B 6
60	14.4	14	16.8	63/2	63B 6
51	16.9	16	15.9	63/2	63B 6
43	19.8	19	13.6	63/2	63B 6
36	24.1	23	10.7	63/2	63B 6
33	26.1	25	10.1	63/2	63B 6
27	31.7	30	8.3	63/2	63B 6
23	36.6	35	7.2	63/2	63B 6
19.8	43.4	40	6.2	63/3	63B 6
18.3	47.0	44	5.8	63/3	63B 6
16.1	53.3	50	5.1	63/3	63B 6
15.0	57.2	53	4.8	63/3	63B 6
13.9	61.8	57	4.4	63/3	63B 6
12.4	69.6	65	3.9	63/3	63B 6
11.4	75.4	70	3.6	63/3	63B 6
10.6	81.4	76	3.4	63/3	63B 6
9.7	88.4	82	3.0	63/3	63B 6
8.7	98.9	92	2.7	63/3	63B 6
7.5	114.4	106	2.4	63/3	63B 6
6.4	135.4	126	2.0	63/3	63B 6
5.8	149.1	139	1.8	63/3	63B 6
5.3	163.2	152	3.1	71/3	63B 6
5.2	164.7	153	1.6	63/3	63B 6
4.7	181.3	169	1.5	63/3	63B 6
4.5	191.6	178	2.9	71/3	63B 6
4.0	216.9	202	1.3	63/3	63B 6
3.9	220.8	205	2.5	71/3	63B 6

0.13 kW	$n_1 = 1360 \text{ min}^{-1}$ $n_1 = 860 \text{ min}^{-1}$	63A 4 63C 6
----------------	---	----------------

94	14.4	12	17.6	63/2	63A 4
80	16.9	15	17.1	63/2	63A 4
69	19.8	17	14.6	63/2	63A 4
56	24.1	21	11.0	63/2	63A 4
52	26.1	23	10.6	63/2	63A 4
43	31.7	27	8.7	63/2	63A 4
37	36.6	32	7.9	63/2	63A 4
31	43.4	37	6.8	63/3	63A 4
26	53.3	45	5.5	63/3	63A 4
24	57.2	49	5.1	63/3	63A 4
22	61.8	52	4.8	63/3	63A 4
19.5	69.6	59	4.2	63/3	63A 4
18.0	75.4	64	3.9	63/3	63A 4
16.7	81.4	69	3.6	63/3	63A 4
15.4	88.4	75	3.3	63/3	63A 4
13.8	98.9	84	3.0	63/3	63A 4
11.9	114.4	97	2.6	63/3	63A 4
10.0	135.4	115	2.2	63/3	63A 4
9.1	149.1	127	2.0	63/3	63A 4
8.3	163.2	139	3.3	71/3	63A 4
8.3	164.7	140	1.8	63/3	63A 4
7.5	181.3	154	1.6	63/3	63A 4
7.1	191.6	163	3.0	71/3	63A 4
6.3	216.9	184	1.4	63/3	63A 4
6.2	220.8	187	2.7	71/3	63A 4
5.3	163.2	219	2.1	71/3	63C 6

1.7 PMP - PCP - PMF - PCF
Gearmotors performances

n_2 min ⁻¹	ir	T2 Nm	FS'	PMP - PCP PMF - PCF	
----------------------------	----	----------	-----	------------------------	--

0.13 kW	$n_1 = 1360 \text{ min}^{-1}$ $n_1 = 860 \text{ min}^{-1}$	63A 4 63C 6
----------------	---	----------------

5.2	164.7	221	1.1	63/3	63C 6
4.0	216.9	291	0.9	63/3	63C 6
3.9	220.8	296	1.8	71/3	63C 6

0.18 kW	$n_1 = 1370 \text{ min}^{-1}$ $n_1 = 870 \text{ min}^{-1}$	63B 4 71A 6
----------------	---	----------------

152	9.0	11	19.6	63/2	63B 4
132	10.4	12	17.7	63/2	63B 4
116	11.8	14	16.7	63/2	63B 4
101	13.5	16	15.5	63/2	63B 4
95	14.4	17	12.8	63/2	63B 4
81	16.9	20	12.4	63/2	63B 4
69	19.8	24	10.6	63/2	63B 4
57	24.1	29	8.0	63/2	63B 4
52	26.1	31	7.7	63/2	63B 4
43	31.7	38	6.4	63/2	63B 4
37	36.6	44	5.7	63/2	63B 4
32	43.4	51	4.9	63/3	63B 4
29	47.0	55	4.6	63/3	63B 4
26	53.3	62	4.0	63/3	63B 4
24	57.2	67	3.7	63/3	63B 4
22	61.8	72	3.5	63/3	63B 4
19.7	69.6	81	3.1	63/3	63B 4
18.2	75.4	88	2.8	63/3	63B 4
16.8	81.4	95	2.6	63/3	63B 4
15.5	88.4	103	2.4	63/3	63B 4
13.9	98.9	115	2.2	63/3	63B 4
12.0	114.4	133	1.9	63/3	63B 4
11.1	123.8	144	3.2	71/3	63B 4
10.2	134.3	157	2.9	71/3	63B 4
10.1	135.4	158	1.6	63/3	63B 4
9.2	149.1	174	1.4	63/3	63B 4
8.9	154.8	181	2.5	71/3	63B 4
8.4	163.2	190	2.4	71/3	63B 4
8.3	164.7	192	1.3	63/3	63B 4
7.6	181.3	212	1.2	63/3	63B 4
7.2	191.6	224	2.2	71/3	63B 4
6.3	216.9	253	1.0	63/3	63B 4
6.2	220.8	258	1.9	71/3	63B 4
5.3	163.2	300	1.6	71/3	71A 6
5.3	164.7	303	0.8	63/3	71A 6
4.9	178.1	327	2.9	90/3	71A 6
3.9	220.8	406	1.3	71/3	71A 6
3.4	253.2	465	2.0	90/3	71A 6

0.22 kW	$n_1 = 1400 \text{ min}^{-1}$	63C 4
----------------	-------------------------------	-------

467	3.0	4	18.7	63/2	63C 4
359	3.9	6	19.8	63/2	63C 4
280	5.0	7	19.6	63/2	63C 4
226	6.2	9	18.1	63/2	63C 4

1.7 Leistungen der PMP - PCP -
PMF - PCF Getriebemotoren

n_2 min ⁻¹	ir	T2 Nm	FS'	PMP - PCP PMF - PCF	
----------------------------	----	----------	-----	------------------------	---

0.22 kW	$n_1 = 1400 \text{ min}^{-1}$	63C 4
----------------	-------------------------------	-------

189	7.4	11	17.1	63/2	63C 4
156	9.0	13	16.4	63/2	63C 4
119	11.8	17	14.0	63/2	63C 4
97	14.4	21	10.7	63/2	63C 4
83	16.9	24	10.4	63/2	63C 4
71	19.8	28	8.9	63/2	63C 4
58	24.1	34	6.7	63/2	63C 4
44	31.7	45	5.3	63/2	63C 4
32	43.4	61	4.1	63/3	63C 4
26	53.3	74	3.4	63/3	63C 4
23	61.8	86	2.9	63/3	63C 4
20	69.6	97	2.6	63/3	63C 4
17.2	81.4	114	2.2	63/3	63C 4
15.8	88.4	123	2.0	63/3	63C 4
14.2	98.9	138	1.8	63/3	63C 4
14.1	99.3	139	3.3	71/3	63C 4
12.2	114.4	160	1.6	63/3	63C 4
11.3	123.8	173	2.7	71/3	63C 4
9.4	149.1	208	1.2	63/3	63C 4
9.0	154.8	216	2.1	71/3	63C 4
7.7	181.3	253	1.0	63/3	63C 4
7.3	191.6	267	1.8	71/3	63C 4
6.5	216.9	303	0.8	63/3	63C 4
6.3	220.8	308	1.6	71/3	63C 4

0.25 kW	$n_1 = 1370 \text{ min}^{-1}$ $n_1 = 870 \text{ min}^{-1}$	71A 4 71B 6
----------------	---	----------------

457	3.0	5	16.1	63/2	71A 4
351	3.9	6	17.0	63/2	71A 4
319	4.3	7	18.3	63/2	71A 4
274	5.0	8	16.9	63/2	71A 4
245	5.6	9	17.3	63/2	71A 4
211	6.5	11	15.8	63/2	71A 4
185	7.4	12	14.7	63/2	71A 4
171	8.0	13	15.1	63/2	71A 4
152	9.0	15	14.1	63/2	71A 4
132	10.4	17	12.8	63/2	71A 4
116	11.8	20	12.0	63/2	71A 4
95	14.4	24	9.2	63/2	71A 4
81	16.9	28	8.9	63/2	71A 4
69	19.8	33	7.6	63/2	71A 4
57	24.1	40	5.8	63/2	71A 4
52	26.1	43	5.6	63/2	71A 4
43	31.7	52	4.6	63/2	71A 4
37	36.6	61	4.1	63/2	71A 4
32	43.4	70	3.6	63/3	71A 4
29	47.0	76	3.3	63/3	71A 4
24	57.2	93	2.7	63/3	71A 4
22	61.8	100	2.5	63/3	71A 4
19.7	69.6	113	2.2	63/3	71A 4
18.2	75.4	122	2.0	63/3	71A 4
16.8	81.4	132	1.9	63/3	71A 4
15.5	88.4	143	1.7	63/3	71A 4
15.0	91.5	148	3.1	71/3	71A 4
13.9	98.9	160	1.6	63/3	71A 4



**1.7 Prestazioni motoriduttori
PMP - PCP - PMF - PCF**

n_2 min ⁻¹	ir	T2 Nm	FS'	PMP - PCP PMF - PCF	
----------------------------	----	----------	-----	------------------------	--

0.25 kW	$n_1 = 1370 \text{ min}^{-1}$	71A 4
	$n_1 = 870 \text{ min}^{-1}$	71B 6

13.8	99.3	161	2.9	71/3	71A 4
12.0	114.4	185	1.3	63/3	71A 4
10.2	134.3	218	2.1	71/3	71A 4
10.1	135.4	219	1.1	63/3	71A 4
9.2	149.1	242	1.0	63/3	71A 4
8.9	154.8	251	1.8	71/3	71A 4
8.4	163.2	265	1.7	71/3	71A 4
8.3	164.7	267	0.9	63/3	71A 4
7.6	181.3	294	0.9	63/3	71A 4
7.2	191.6	311	1.6	71/3	71A 4
6.8	201.0	326	2.8	90/3	71A 4
6.2	220.8	358	1.4	71/3	71A 4
5.4	253.2	410	2.2	90/3	71A 4
5.3	163.2	417	1.1	71/3	71B 6
4.5	191.6	489	1.1	71/3	71B 6
4.3	201.0	513	1.8	90/3	71B 6
3.4	253.2	646	1.5	90/3	71B 6

0.37 kW	$n_1 = 2790 \text{ min}^{-1}$	63C 2
	$n_1 = 1380 \text{ min}^{-1}$	71B 4
	$n_1 = 910 \text{ min}^{-1}$	80A 6
	$n_1 = 880 \text{ min}^{-1}$	71C 6

715	3.9	5	19.2	63/2	63C 2
649	4.3	5	18.4	63/2	63C 2
558	5.0	6	18.3	63/2	63C 2
498	5.6	7	18.6	63/2	63C 2
460	3.0	7	11.0	63/2	71B 4
431	3.2	8	19.3	71/2	71B 4
354	3.9	9	11.6	63/2	71B 4
321	4.3	10	12.4	63/2	71B 4
276	5.0	12	11.5	63/2	71B 4
246	5.6	14	11.7	63/2	71B 4
223	6.2	15	10.6	63/2	71B 4
212	6.5	16	10.8	63/2	71B 4
173	8.0	19	10.3	63/2	71B 4
153	9.0	22	9.6	63/2	71B 4
133	10.4	25	8.7	63/2	71B 4
117	11.8	29	8.2	63/2	71B 4
102	13.5	33	7.6	63/2	71B 4
96	14.4	35	6.3	63/2	71B 4
82	16.9	41	6.1	63/2	71B 4
70	19.8	48	5.2	63/2	71B 4
57	24.1	59	3.9	63/2	71B 4
53	26.1	63	3.8	63/2	71B 4
44	31.7	77	3.1	63/2	71B 4
38	36.6	89	2.8	63/2	71B 4
32	43.4	103	2.4	63/3	71B 4
29	47.0	112	2.2	63/3	71B 4
26	53.3	127	2.0	63/3	71B 4
23	60.8	145	3.2	71/3	71B 4
22	61.8	147	1.7	63/3	71B 4
19.8	69.6	166	1.5	63/3	71B 4
18.3	75.4	180	2.6	71/3	71B 4
18.3	75.4	180	1.4	63/3	71B 4
15.9	86.8	207	2.2	71/3	71B 4
15.6	88.4	211	1.2	63/3	71B 4

**1.7 PMP - PCP - PMF - PCF
Gearmotors performances**

n_2 min ⁻¹	ir	T2 Nm	FS'	PMP - PCP PMF - PCF	
----------------------------	----	----------	-----	------------------------	--

0.37 kW	$n_1 = 2790 \text{ min}^{-1}$	63C 2
	$n_1 = 1380 \text{ min}^{-1}$	71B 4
	$n_1 = 910 \text{ min}^{-1}$	80A 6
	$n_1 = 880 \text{ min}^{-1}$	71C 6

14.0	98.9	236	1.1	63/3	71B 4
13.9	99.3	236	1.9	71/3	71B 4
12.8	107.5	256	1.8	71/3	71B 4
12.1	114.4	272	0.9	63/3	71B 4
11.1	123.8	295	1.6	71/3	71B 4
11.0	125.0	298	3.1	90/3	71B 4
10.3	134.3	320	1.4	71/3	71B 4
9.8	141.0	336	2.7	90/3	71B 4
8.9	154.8	369	1.2	71/3	71B 4
8.9	155.2	370	2.5	90/3	71B 4
7.2	191.6	456	1.1	71/3	71B 4
6.9	201.0	479	1.9	90/3	71B 4
6.3	220.8	526	1.0	71/3	71B 4
5.5	253.2	603	1.5	90/3	71B 4
4.4	201.0	751	1.3	90/3	71C 6
4.1	220.9	798	2.3	112/3	80A 6
3.5	253.2	946	1.0	90/3	71C 6
3.3	278.1	1004	1.9	112/3	80A 6

0.55 kW	$n_1 = 2800 \text{ min}^{-1}$	71B 2
	$n_1 = 1380 \text{ min}^{-1}$	71C 4
	$n_1 = 1390 \text{ min}^{-1}$	80A 4
	$n_1 = 910 \text{ min}^{-1}$	80B 6

933	3.0	5	14.4	63/2	71B 2
718	3.9	7	12.9	63/2	71B 2
651	4.3	8	12.4	63/2	71B 2
531	2.6	9	13.8	71/2	71C 4
460	3.0	11	7.4	63/2	71C 4
431	3.2	12	13.0	71/2	71C 4
363	3.8	14	12.7	71/2	71C 4
354	3.9	14	7.8	63/2	71C 4
321	4.3	16	8.4	63/2	71C 4
276	5.0	18	7.7	63/2	71C 4
246	5.6	20	7.9	63/2	71C 4
223	6.2	22	7.1	63/2	71C 4
212	6.5	24	7.2	63/2	71C 4
186	7.4	27	6.7	63/2	71C 4
173	8.0	29	6.9	63/2	71C 4
153	9.0	33	6.5	63/2	71C 4
133	10.4	38	5.9	63/2	71C 4
117	11.8	43	5.5	63/2	71C 4
102	13.5	49	5.1	63/2	71C 4
96	14.4	52	4.2	63/2	71C 4
82	16.9	61	4.1	63/2	71C 4
70	19.8	72	3.5	63/2	71C 4
67	20.5	74	3.1	63/2	71C 4
57	24.1	87	2.6	63/2	71C 4
53	26.1	94	2.5	63/2	71C 4
44	31.7	115	2.1	63/2	71C 4
42	33.1	120	3.4	71/2	71C 4
38	36.6	132	1.9	63/2	71C 4
37	37.3	135	3.0	71/2	71C 4
35	39.5	140	3.3	71/3	71C 4
32	43.4	154	1.6	63/3	71C 4
31	44.7	162	2.8	71/2	71C 4
29	47.0	166	1.5	63/3	71C 4
27	50.5	183	2.5	71/2	71C 4

**1.7 Leistungen der PMP - PCP -
PMF - PCF Getriebemotoren**

n_2 min ⁻¹	ir	T2 Nm	FS'	PMP - PCP PMF - PCF	
----------------------------	----	----------	-----	------------------------	--

0.55 kW	$n_1 = 2800 \text{ min}^{-1}$	71B 2
	$n_1 = 1380 \text{ min}^{-1}$	71C 4
	$n_1 = 1390 \text{ min}^{-1}$	80A 4
	$n_1 = 910 \text{ min}^{-1}$	80B 6

26	53.3	189	1.3	63/3	71C 4
26	53.5	189	2.4	71/3	71C 4
23	60.8	215	2.1	71/3	71C 4
22	61.8	219	1.1	63/3	71C 4
21	64.2	227	2.0	71/3	71C 4
19.8	69.6	246	1.0	63/3	71C 4
18.3	75.4	267	1.7	71/3	71C 4
18.3	75.4	267	0.9	63/3	71C 4
18.1	76.3	270	3.4	90/3	71C 4
17.0	81.4	288	0.9	63/3	71C 4
16.7	82.8	293	3.1	90/3	71C 4
15.1	91.5	324	1.4	71/3	71C 4
14.8	93.3	330	2.8	90/3	71C 4
13.9	99.3	351	1.3	71/3	71C 4
13.7	100.6	356	2.6	90/3	71C 4
12.8	107.5	381	1.2	71/3	71C 4
12.7	108.9	385	2.4	90/3	71C 4
11.1	123.8	438	1.0	71/3	71C 4
11.0	125.0	442	2.1	90/3	71C 4
10.3	134.3	475	1.0	71/3	71C 4
9.8	141.0	499	1.8	90/3	71C 4
8.9	154.8	548	0.8	71/3	71C 4
8.9	155.2	549	1.7	90/3	71C 4
8.3	167.0	587	3.0	112/3	80A 4
7.7	178.1	630	1.4	90/3	71C 4
6.3	220.9	776	2.3	112/3	80A 4
6.1	224.4	794	1.1	90/3	71C 4
5.8	241.0	847	2.1	112/3	80A 4
5.5	253.2	896	1.0	90/3	71C 4
4.8	191.5	1028	1.8	112/3	80B 6
4.5	201.0	1079	0.9	90/3	80B 6
3.3	278.1	1493	1.3	112/3	80B 6

0.75 kW	$n_1 = 2800 \text{ min}^{-1}$	71C 2
	$n_1 = 1390 \text{ min}^{-1}$	80B 4
	$n_1 = 910 \text{ min}^{-1}$	80C 6

933	3.0	7	10.6	63/2	71C 2
718	3.9	9	9.5	63/2	71C 2
651	4.3	10	9.1	63/2	71C 2
560	5.0	12	9.1	63/2	71C 2
500	5.6	14	9.2	63/2	71C 2
452	6.2	15	8.6	63/2	71C 2
431	6.5	16	8.5	63/2	71C 2
378	7.4	18	7.8	63/2	71C 2
356	3.9	19	5.8	63/2	80B 4
323	4.3	21	6.2	63/2	80B 4
278	5.0	24	5.7	63/2	80B 4
248	5.6	27	5.8	63/2	80B 4
224	6.2	30	5.3	63/2	80B 4
214	6.5	32	5.3	63/2	80B 4
188	7.4	36	5.0	63/2	80B 4
174	8.0	39	5.1	63/2	80B 4
154	9.0	44	4.8	63/2	80B 4
134	10.4	51	4.3	63/2	80B 4
118	11.8	58	4.1	63/2	80B 4
97	14.4	70	3.1	63/2	80B 4



1.7 Prestazioni motoriduttori
PMP - PCP - PMF - PCF

n_2 min ⁻¹	ir	T2 Nm	FS'	PMP - PCP PMF - PCF	
----------------------------	----	----------	-----	------------------------	--

0.75 kW	$n_1 = 2800 \text{ min}^{-1}$	71C 2
	$n_1 = 1390 \text{ min}^{-1}$	80B 4
	$n_1 = 910 \text{ min}^{-1}$	80C 6

82	16.9	83	3.0	63/2	80B 4
70	19.8	97	2.6	63/2	80B 4
58	24.1	118	1.9	63/2	80B 4
55	25.3	124	3.3	71/2	80B 4
53	26.1	128	1.9	63/2	80B 4
48	28.8	141	3.3	71/2	80B 4
44	31.7	155	1.5	63/2	80B 4
42	33.1	162	2.5	71/2	80B 4
38	36.6	179	1.4	63/2	80B 4
37	37.3	183	2.2	71/2	80B 4
35	39.5	189	2.4	71/3	80B 4
32	43.4	208	1.2	63/3	80B 4
30	47.0	225	1.1	63/3	80B 4
28	50.5	247	1.9	71/2	80B 4
26	53.3	255	1.0	63/3	80B 4
25	55.2	265	3.4	90/3	80B 4
24	57.2	274	0.9	63/3	80B 4
23	60.8	291	1.6	71/3	80B 4
22	61.8	296	0.8	63/3	80B 4
22	62.3	299	3.0	90/3	80B 4
22	64.2	308	1.5	71/3	80B 4
18.4	75.4	361	1.3	71/3	80B 4
18.2	76.3	366	2.5	90/3	80B 4
16.8	82.8	397	2.3	90/3	80B 4
16.0	86.8	416	1.1	71/3	80B 4
15.2	91.5	438	1.0	71/3	80B 4
14.9	93.3	447	2.0	90/3	80B 4
12.9	107.5	515	0.9	71/3	80B 4
12.8	108.4	519	3.4	112/3	80B 4
10.8	128.3	615	2.8	112/3	80B 4
9.9	141.0	676	1.3	90/3	80B 4
8.3	167.0	800	2.2	112/3	80B 4
7.8	178.1	853	1.1	90/3	80B 4
6.3	220.9	1059	1.7	112/3	80B 4
6.2	224.4	1075	0.8	90/3	80B 4
5.0	278.1	1333	1.3	112/3	80B 4
4.1	220.9	1617	1.2	112/3	80C 6
3.3	278.1	2036	0.9	112/3	80C 6

0.88 kW	$n_1 = 1350 \text{ min}^{-1}$	80C 4

450	3.0	18	4.5	63/2	80C 4
346	3.9	23	4.8	63/2	80C 4
314	4.3	25	5.1	63/2	80C 4
270	5.0	30	4.7	63/2	80C 4
241	5.6	33	4.8	63/2	80C 4
218	6.2	37	4.4	63/2	80C 4
208	6.5	38	4.4	63/2	80C 4
182	7.4	44	4.1	63/2	80C 4
169	8.0	47	4.2	63/2	80C 4
150	9.0	53	3.9	63/2	80C 4
130	10.4	62	3.6	63/2	80C 4
114	11.8	70	3.4	63/2	80C 4
100	13.5	80	3.1	63/2	80C 4
94	14.4	85	2.6	63/2	80C 4

1.7 PMP - PCP - PMF - PCF
Gearmotors performances

n_2 min ⁻¹	ir	T2 Nm	FS'	PMP - PCP PMF - PCF	
----------------------------	----	----------	-----	------------------------	--

0.88 kW	$n_1 = 1350 \text{ min}^{-1}$	80C 4

80	16.9	100	2.5	63/2	80C 4
68	19.8	117	2.1	63/2	80C 4
66	20.5	121	1.9	63/2	80C 4
56	24.1	143	1.6	63/2	80C 4
53	25.3	150	2.7	71/2	80C 4
43	31.7	187	1.3	63/2	80C 4
41	33.1	196	2.1	71/2	80C 4
34	39.5	229	2.0	71/3	80C 4
31	43.4	251	1.0	63/3	80C 4
29	47.0	272	0.9	63/3	80C 4
28	48.8	283	3.2	90/3	80C 4
27	50.5	299	1.5	71/2	80C 4
22	60.8	352	1.3	71/3	80C 4
22	62.3	361	2.5	90/3	80C 4
17.9	75.4	437	1.1	71/3	80C 4
17.7	76.3	442	2.1	90/3	80C 4
16.3	82.8	479	1.9	90/3	80C 4
15.6	86.8	503	0.9	71/3	80C 4
14.8	91.5	530	0.9	71/3	80C 4
14.5	93.3	540	1.7	90/3	80C 4
14.4	93.6	542	3.2	112/3	80C 4
13.6	99.3	575	0.8	71/3	80C 4
13.4	100.6	582	1.6	90/3	80C 4
12.5	108.4	628	2.8	112/3	80C 4
12.4	108.9	630	1.4	90/3	80C 4
11.5	117.2	679	2.6	112/3	80C 4
10.8	125.0	724	1.3	90/3	80C 4
9.1	148.0	857	2.0	112/3	80C 4
8.7	155.2	899	1.0	90/3	80C 4
7.6	178.1	1031	0.9	90/3	80C 4
7.0	191.5	1109	1.6	112/3	80C 4
6.1	220.9	1279	1.4	112/3	80C 4
4.9	278.1	1610	1.1	112/3	80C 4

1.1 kW	$n_1 = 2830 \text{ min}^{-1}$	80B 2
	$n_1 = 1390 \text{ min}^{-1}$	80D 4

943	3.0	11	7.3	63/2	80B 2
726	3.9	14	6.5	63/2	80B 2
658	4.3	15	6.3	63/2	80B 2
566	5.0	18	6.2	63/2	80B 2
505	5.6	20	6.3	63/2	80B 2
463	3.0	22	3.7	63/2	80D 4
356	3.9	28	3.9	63/2	80D 4
323	4.3	31	4.2	63/2	80D 4
278	5.0	36	3.9	63/2	80D 4
248	5.6	40	4.0	63/2	80D 4
224	6.2	45	3.6	63/2	80D 4
214	6.5	47	3.6	63/2	80D 4
188	7.4	53	3.4	63/2	80D 4
174	8.0	57	3.5	63/2	80D 4
154	9.0	65	3.2	63/2	80D 4
134	10.4	75	2.9	63/2	80D 4
118	11.8	85	2.8	63/2	80D 4
103	13.5	97	2.6	63/2	80D 4

1.7 Leistungen der PMP - PCP -
PMF - PCF Getriebemotoren

n_2 min ⁻¹	ir	T2 Nm	FS'	PMP - PCP PMF - PCF	
----------------------------	----	----------	-----	------------------------	--

1.1 kW	$n_1 = 2830 \text{ min}^{-1}$	80B 2
	$n_1 = 1390 \text{ min}^{-1}$	80D 4
	$n_1 = 1400 \text{ min}^{-1}$	90S 4
	$n_1 = 920 \text{ min}^{-1}$	90L 6

97	14.4	103	2.1	63/2	80D 4
82	16.9	121	2.1	63/2	80D 4
74	18.7	134	3.4	71/2	80D 4
70	19.8	142	1.8	63/2	80D 4
69	20.2	145	3.2	71/2	80D 4
68	20.5	147	1.6	63/2	80D 4
63	21.9	157	2.9	71/2	80D 4
58	24.1	173	1.3	63/2	80D 4
53	26.1	187	1.3	63/2	80D 4
48	28.8	207	2.2	71/2	80D 4
44	31.7	228	1.1	63/2	80D 4
42	33.1	238	1.7	71/2	80D 4
38	36.6	263	1.0	63/2	80D 4
37	37.3	268	1.5	71/2	80D 4
36	38.7	272	3.3	90/3	80D 4
35	39.5	278	1.7	71/3	80D 4
32	43.4	305	0.8	63/3	80D 4
32	43.7	307	3.0	90/3	80D 4
31	44.7	321	1.4	71/2	80D 4
28	48.8	343	2.7	90/3	80D 4
28	50.5	363	1.3	71/2	80D 4
26	53.5	376	1.2	71/3	80D 4
25	55.2	388	2.3	90/3	80D 4
23	60.8	427	1.1	71/3	80D 4
22	62.3	438	2.1	90/3	80D 4
22	64.2	451	1.0	71/3	80D 4
19.7	70.6	496	1.8	90/3	80D 4
19.1	72.6	510	3.4	112/3	80D 4
18.4	75.4	530	0.9	71/3	80D 4
18.2	76.3	536	1.7	90/3	80D 4
17.7	78.5	552	3.2	112/3	80D 4
16.8	82.8	582	1.6	90/3	80D 4
15.9	87.3	614	2.9	112/3	80D 4
14.9	93.3	656	1.4	90/3	80D 4
14.9	93.6	658	2.7	112/3	80D 4
13.8	100.6	707	1.3	90/3	80D 4
12.8	108.4	762	2.3	112/3	80D 4
11.9	117.2	824	2.1	112/3	80D 4
11.1	125.0	879	1.0	90/3	80D 4
10.8	128.3	902	1.9	112/3	80D 4
9.9	141.0	991	0.9	90/3	80D 4
9.4	148.0	1040	1.7	112/3	80D 4
9.0	155.2	1091	0.8	90/3	80D 4
8.3	167.0	1174	1.5	112/3	80D 4
7.3	191.5	1346	1.3	112/3	80D 4
6.3	220.9	1553	1.1	112/3	80D 4
5.8	241.0	1694	1.0	112/3	80D 4
5.0	278.1	1955	0.9	112/3	80D 4



**1.7 Prestazioni motoriduttori
PMP - PCP - PMF - PCF**

n_2 min ⁻¹	ir	T2 Nm	FS'	PMP - PCP PMF - PCF	
----------------------------	----	----------	-----	------------------------	---

1.5 kW		$n_1 = 2830 \text{ min}^{-1}$ $n_1 = 1400 \text{ min}^{-1}$	80C 2 90L 4
---------------	--	--	----------------

943	3.0	14	5.3	63/2	80C 2
884	3.2	15	9.1	71/2	80C 2
726	3.9	19	4.8	63/2	80C 2
658	4.3	21	4.6	63/2	80C 2
566	5.0	24	4.6	63/2	80C 2
505	5.6	27	4.6	63/2	80C 2
467	3.0	29	2.7	63/2	90L 4
359	3.9	38	2.9	63/2	90L 4
326	4.3	42	3.1	63/2	90L 4
280	5.0	49	2.9	63/2	90L 4
250	5.6	54	2.9	63/2	90L 4
226	6.2	60	2.7	63/2	90L 4
215	6.5	63	2.7	63/2	90L 4
189	7.4	72	2.5	63/2	90L 4
175	8.0	78	2.6	63/2	90L 4
156	9.0	87	2.4	63/2	90L 4
135	10.4	101	2.2	63/2	90L 4
119	11.8	115	2.0	63/2	90L 4
114	12.3	120	2.5	71/2	90L 4
104	13.5	131	1.9	63/2	90L 4
100	14.0	136	3.3	71/2	90L 4
97	14.4	140	1.6	63/2	90L 4
87	16.1	157	2.9	71/2	90L 4
83	16.9	164	1.5	63/2	90L 4
81	17.3	168	2.7	71/2	90L 4
75	18.7	182	2.5	71/2	90L 4
71	19.8	192	1.3	63/2	90L 4
69	20.2	196	2.3	71/2	90L 4
68	20.5	199	1.2	63/2	90L 4
64	21.9	213	2.2	71/2	90L 4
58	24.1	234	1.0	63/2	90L 4
55	25.3	246	1.7	71/2	90L 4
54	26.1	254	0.9	63/2	90L 4
49	28.8	280	1.6	71/2	90L 4
46	30.5	296	3.1	90/2	90L 4
42	33.1	322	1.3	71/2	90L 4
40	35.0	340	2.5	90/2	90L 4
38	37.3	363	1.1	71/2	90L 4
35	39.5	376	1.2	71/3	90L 4
32	44.1	429	2.0	90/2	90L 4
31	44.7	435	1.1	71/2	90L 4
28	50.5	491	0.9	71/2	90L 4
28	50.9	495	1.7	90/2	90L 4
26	53.5	509	0.9	71/3	90L 4
25	55.2	525	1.7	90/3	90L 4
24	58.5	557	3.1	112/3	90L 4
22	62.3	593	1.5	90/3	90L 4
22	62.7	597	2.9	112/3	90L 4
19.8	70.6	672	1.4	90/3	90L 4
19.3	72.6	691	2.5	112/3	90L 4
18.3	76.3	726	1.3	90/3	90L 4
17.8	78.5	747	2.3	112/3	90L 4
16.9	82.8	788	1.2	90/3	90L 4
16.0	87.3	831	2.1	112/3	90L 4
15.0	93.3	888	1.0	90/3	90L 4
15.0	93.6	891	2.0	112/3	90L 4
13.9	100.6	957	1.0	90/3	90L 4
12.9	108.4	1032	1.7	112/3	90L 4
12.9	108.9	1036	0.9	90/3	90L 4

**1.7 PMP - PCP - PMF - PCF
Gearmotors performances**

n_2 min ⁻¹	ir	T2 Nm	FS'	PMP - PCP PMF - PCF	
----------------------------	----	----------	-----	------------------------	--

1.5 kW		$n_1 = 2830 \text{ min}^{-1}$ $n_1 = 1400 \text{ min}^{-1}$	580C 2 90L 4
---------------	--	--	-----------------

11.9	117.2	1115	1.6	112/3	90L 4
10.9	128.3	1221	1.4	112/3	90L 4
9.5	148.0	1408	1.2	112/3	90L 4
8.4	167.0	1589	1.1	112/3	90L 4
7.3	191.5	1822	1.0	112/3	90L 4
6.3	220.9	2102	0.8	112/3	90L 4

1.8 kW		$n_1 = 2770 \text{ min}^{-1}$ $n_1 = 1400 \text{ min}^{-1}$	80D 2 90LB 4
---------------	--	--	-----------------

923	3.0	18	4.4	63/2	80D 2
710	3.9	23	3.9	63/2	80D 2
644	4.3	25	3.7	63/2	80D 2
554	5.0	29	3.7	63/2	80D 2
467	3.0	35	2.3	63/2	90LB 4
359	3.9	45	2.4	63/2	90LB 4
326	4.3	50	2.6	63/2	90LB 4
280	5.0	58	2.4	63/2	90LB 4
264	5.3	62	3.4	71/2	90LB 4
250	5.6	65	2.4	63/2	90LB 4
226	6.2	72	2.2	63/2	90LB 4
215	6.5	76	2.2	63/2	90LB 4
189	7.4	86	2.1	63/2	90LB 4
175	8.0	93	2.1	63/2	90LB 4
161	8.7	101	3.1	71/2	90LB 4
156	9.0	105	2.0	63/2	90LB 4
121	11.6	135	3.2	71/2	90LB 4
119	11.8	138	1.7	63/2	90LB 4
114	12.3	143	2.1	71/2	90LB 4
104	13.5	157	1.6	63/2	90LB 4
100	14.0	163	2.8	71/2	90LB 4
97	14.4	168	1.3	63/2	90LB 4
87	16.1	188	2.4	71/2	90LB 4
83	16.9	197	1.3	63/2	90LB 4
81	17.3	202	2.3	71/2	90LB 4
75	18.7	218	2.1	71/2	90LB 4
71	19.8	231	1.1	63/2	90LB 4
69	20.2	236	2.0	71/2	90LB 4
68	20.5	239	1.0	63/2	90LB 4
64	21.9	255	1.8	71/2	90LB 4
58	24.1	281	0.8	63/2	90LB 4
56	25.0	292	3.1	90/2	90LB 4
55	25.3	295	1.4	71/2	90LB 4
51	27.7	323	2.8	90/2	90LB 4
49	28.8	336	1.4	71/2	90LB 4
46	30.5	356	2.6	90/2	90LB 4
42	33.1	386	1.1	71/2	90LB 4
38	37.3	435	0.9	71/2	90LB 4
35	39.5	451	1.0	71/3	90LB 4
35	40.4	471	1.5	90/2	90LB 4
32	44.1	514	1.7	90/2	90LB 4
31	44.7	521	0.9	71/2	90LB 4
28	50.9	594	1.4	90/2	90LB 4
27	51.2	585	2.9	112/3	90LB 4
22	62.3	711	1.3	90/3	90LB 4
22	62.7	716	2.4	112/3	90LB 4
19.8	70.6	806	1.1	90/3	90LB 4

**1.7 Leistungen der PMP - PCP -
PMF - PCF Getriebemotoren**

n_2 min ⁻¹	ir	T2 Nm	FS'	PMP - PCP PMF - PCF	
----------------------------	----	----------	-----	------------------------	---

1.8 kW		$n_1 = 2770 \text{ min}^{-1}$ $n_1 = 1400 \text{ min}^{-1}$	80D 2 90LB 4
---------------	--	--	-----------------

19.3	72.6	829	2.1	112/3	90LB 4
18.3	76.3	871	1.0	90/3	90LB 4
17.8	78.5	896	2.0	112/3	90LB 4
16.9	82.8	945	1.0	90/3	90LB 4
16.0	87.3	997	1.8	112/3	90LB 4
15.0	93.3	1065	0.9	90/3	90LB 4
15.0	93.6	1069	1.6	112/3	90LB 4
12.9	108.4	1238	1.4	112/3	90LB 4
11.9	117.2	1338	1.3	112/3	90LB 4
10.9	128.3	1465	1.2	112/3	90LB 4
9.5	148.0	1690	1.0	112/3	90LB 4
8.4	167.0	1907	0.9	112/3	90LB 4
7.3	191.5	2187	0.8	112/3	90LB 4

2.2 kW		$n_1 = 2840 \text{ min}^{-1}$ $n_1 = 1410 \text{ min}^{-1}$	90L 2 100A 4
---------------	--	--	-----------------

1092	2.6	18	6.6	71/2	90L 2
947	3.0	21	3.7	63/2	90L 2
888	3.2	22	6.2	71/2	90L 2
728	3.9	27	3.3	63/2	90L 2
660	4.3	30	3.1	63/2	90L 2
568	5.0	35	3.1	63/2	90L 2
507	5.6	39	3.2	63/2	90L 2
470	3.0	42	1.9	63/2	100A 4
441	3.2	45	3.3	71/2	100A 4
437	6.5	46	3.0	63/2	90L 2
371	3.8	54	3.3	71/2	100A 4
362	3.9	55	2.0	63/2	100A 4
328	4.3	61	3.3	71/2	100A 4
328	4.3	61	2.1	63/2	100A 4
282	5.0	71	2.0	63/2	100A 4
266	5.3	75	2.8	71/2	100A 4
252	5.6	79	2.0	63/2	100A 4
227	6.2	88	3.0	71/2	100A 4
227	6.2	88	1.8	63/2	100A 4
217	6.5	92	1.8	63/2	100A 4
199	7.1	101	3.0	71/2	100A 4
191	7.4	105	1.7	63/2	100A 4
176	8.0	113	1.8	63/2	100A 4
162	8.7	123	2.5	71/2	100A 4
157	9.0	127	1.6	63/2	100A 4
138	10.2	144	2.9	71/2	100A 4
136	10.4	147	1.5	63/2	100A 4
122	11.6	164	2.6	71/2	100A 4
119	11.8	167	1.4	63/2	100A 4
115	12.3	174	1.7	71/2	100A 4
104	13.5	191	1.3	63/2	100A 4
101	14.0	198	2.3	71/2	100A 4
98	14.4	204	1.1	63/2	100A 4
88	16.1	228	2.0	71/2	100A 4
83	16.9	239	1.0	63/2	100A 4
75	18.7	265	1.7	71/2	100A 4
71	19.8	280	3.2	90/2	100A 4
71	19.8	280	0.9	63/2	100A 4
70	20.2	286	1.6	71/2	100A 4
64	21.9	310	1.5	71/2	100A 4



1.7 Prestazioni motoriduttori
PMP - PCP - PMF - PCF

n_2 min ⁻¹	ir	T2 Nm	FS'	PMP - PCP PMF - PCF	
----------------------------	----	----------	-----	------------------------	---

2.2 kW	$n_1 = 2840 \text{ min}^{-1}$ $n_1 = 1410 \text{ min}^{-1}$	90L 2 100A 4
---------------	--	-----------------

56	25.0	354	2.6	90/2	100A 4
56	25.3	358	1.1	71/2	100A 4
51	27.7	392	2.3	90/2	100A 4
49	28.8	408	1.1	71/2	100A 4
46	30.5	432	2.1	90/2	100A 4
43	33.1	469	0.9	71/2	100A 4
40	35.0	495	1.7	90/2	100A 4
35	40.4	572	1.3	90/2	100A 4
35	40.7	576	3.0	112/2	100A 4
28	50.9	721	1.2	90/2	100A 4
28	51.2	710	2.4	112/3	100A 4
23	62.3	863	1.1	90/3	100A 4
22	62.7	869	2.0	112/3	100A 4
21	67.4	934	1.9	112/3	100A 4
20	141.0	970	0.9	90/3	90L 2
18.5	76.3	1057	0.9	90/3	100A 4
18.0	78.5	1088	1.6	112/3	100A 4
16.2	87.3	1210	1.4	112/3	100A 4
15.1	93.6	1297	1.3	112/3	100A 4
13.0	108.4	1502	1.2	112/3	100A 4
12.0	117.2	1624	1.1	112/3	100A 4
11.0	128.3	1778	1.0	112/3	100A 4
9.5	148.0	2051	0.9	112/3	100A 4

3 kW	$n_1 = 2840 \text{ min}^{-1}$ $n_1 = 1420 \text{ min}^{-1}$	90LB 2 100B 4
-------------	--	------------------

1092	2.6	25	4.8	71/2	90LB 2
947	3.0	29	2.7	63/2	90LB 2
888	3.2	31	4.6	71/2	90LB 2
728	3.9	37	2.4	63/2	90LB 2
660	4.3	41	2.3	63/2	90LB 2
568	5.0	48	2.3	63/2	90LB 2
546	2.6	50	2.6	71/2	100B 4
473	3.0	58	1.4	63/2	100B 4
444	3.2	61	2.4	71/2	100B 4
374	3.8	73	2.4	71/2	100B 4
364	3.9	75	1.5	63/2	100B 4
330	4.3	82	2.4	71/2	100B 4
330	4.3	82	1.6	63/2	100B 4
284	5.0	96	1.5	63/2	100B 4
268	5.3	102	2.1	71/2	100B 4
254	5.6	107	1.5	63/2	100B 4
229	6.2	119	2.2	71/2	100B 4
229	6.2	119	1.3	63/2	100B 4
218	6.5	125	1.4	63/2	100B 4
200	7.1	136	2.2	71/2	100B 4
192	7.4	142	1.3	63/2	100B 4
178	8.0	153	1.3	63/2	100B 4
163	8.7	167	3.4	90/2	100B 4
163	8.7	167	1.9	71/2	100B 4
158	9.0	173	1.2	63/2	100B 4
153	9.3	178	3.1	90/2	100B 4
137	10.4	199	1.1	63/2	100B 4
122	11.6	222	1.9	71/2	100B 4
120	11.8	226	1.0	63/2	100B 4
115	12.3	236	1.3	71/2	100B 4

1.7 PMP - PCP - PMF - PCF
Gearmotors performances

n_2 min ⁻¹	ir	T2 Nm	FS'	PMP - PCP PMF - PCF	
----------------------------	----	----------	-----	------------------------	--

3 kW	$n_1 = 2840 \text{ min}^{-1}$ $n_1 = 1420 \text{ min}^{-1}$	90LB 2 100B 4
-------------	--	------------------

105	13.5	259	1.0	63/2	100B 4
101	14.0	268	3.4	90/2	100B 4
101	14.0	268	1.7	71/2	100B 4
89	16.0	307	3.0	90/2	100B 4
88	16.1	309	1.5	71/2	100B 4
83	17.1	328	2.8	90/2	100B 4
82	17.3	332	1.4	71/2	100B 4
76	18.7	358	1.3	71/2	100B 4
72	19.8	380	2.4	90/2	100B 4
70	20.2	387	1.2	71/2	100B 4
66	21.4	410	2.2	90/2	100B 4
65	21.9	420	1.1	71/2	100B 4
57	25.0	479	1.9	90/2	100B 4
56	25.3	485	0.8	71/2	100B 4
56	25.4	487	3.3	112/2	100B 4
51	27.7	531	1.7	90/2	100B 4
49	28.8	552	0.8	71/2	100B 4
49	29.1	558	3.1	112/2	100B 4
41	35.0	671	1.3	90/2	100B 4
35	40.4	774	0.9	90/2	100B 4
35	40.7	780	2.2	112/2	100B 4
32	44.1	845	1.0	90/2	100B 4
32	44.7	857	2.0	112/2	100B 4
28	50.9	976	0.9	90/2	100B 4
28	51.2	961	1.8	112/3	100B 4
23	62.7	1176	1.5	112/3	100B 4
19.6	72.6	1362	1.3	112/3	100B 4
18.1	78.5	1473	1.2	112/3	100B 4
16.3	87.3	1638	1.1	112/3	100B 4
15.2	93.6	1756	1.0	112/3	100B 4
13.1	108.4	2034	0.9	112/3	100B 4

4 kW	$n_1 = 2860 \text{ min}^{-1}$ $n_1 = 1410 \text{ min}^{-1}$	100B 2 100BL 4
-------------	--	-------------------

1100	2.6	33	3.6	71/2	100B 2
953	3.0	38	2.0	63/2	100B 2
894	3.2	41	3.4	71/2	100B 2
753	3.8	48	3.3	71/2	100B 2
733	3.9	49	1.8	63/2	100B 2
665	4.3	55	3.3	71/2	100B 2
665	4.3	55	1.7	63/2	100B 2
542	2.6	67	1.9	71/2	100BL 4
470	3.0	77	1.0	63/2	100BL 4
441	3.2	82	1.8	71/2	100BL 4
371	3.8	98	1.8	71/2	100BL 4
362	3.9	100	1.1	63/2	100BL 4
328	4.3	111	1.8	71/2	100BL 4
328	4.3	111	1.2	63/2	100BL 4
282	5.0	129	1.1	63/2	100BL 4
266	5.3	136	1.5	71/2	100BL 4
252	5.6	144	1.1	63/2	100BL 4
227	6.2	160	1.6	71/2	100BL 4
227	6.2	160	1.0	63/2	100BL 4
199	7.1	183	1.6	71/2	100BL 4
191	7.4	190	0.9	63/2	100BL 4
181	7.8	201	3.2	90/2	100BL 4

1.7 Leistungen der PMP - PCP -
PMF - PCF Getriebemotoren

n_2 min ⁻¹	ir	T2 Nm	FS'	PMP - PCP PMF - PCF	
----------------------------	----	----------	-----	------------------------	---

4 kW	$n_1 = 2860 \text{ min}^{-1}$ $n_1 = 1410 \text{ min}^{-1}$	100B 2 100BL 4
-------------	--	-------------------

176	8.0	206	1.0	63/2	100BL 4
162	8.7	224	2.5	90/2	100BL 4
162	8.7	224	1.4	71/2	100BL 4
157	9.0	232	0.9	63/2	100BL 4
147	9.7	247	3.3	90/2	112A 4
138	10.2	263	1.6	71/2	100BL 4
136	10.4	268	0.8	63/2	100BL 4
129	10.9	281	3.1	90/2	100BL 4
122	11.6	299	1.4	71/2	100BL 4
115	12.3	317	2.9	90/2	100BL 4
115	12.3	317	0.9	71/2	100BL 4
101	14.0	360	2.5	90/2	100BL 4
101	14.0	360	1.2	71/2	100BL 4
88	16.0	412	2.2	90/2	100BL 4
88	16.1	414	1.1	71/2	100BL 4
82	17.1	440	2.1	90/2	100BL 4
82	17.3	445	1.0	71/2	100BL 4
75	18.7	481	1.0	71/2	100BL 4
71	19.8	510	1.8	90/2	100BL 4
66	21.4	551	1.7	90/2	100BL 4
64	21.9	564	0.8	71/2	100BL 4
56	25.0	643	1.4	90/2	100BL 4
56	25.4	654	2.5	112/2	100BL 4
51	27.7	713	1.3	90/2	100BL 4
48	29.1	749	2.3	112/2	100BL 4
46	30.5	785	1.2	90/2	100BL 4
40	35.0	901	0.9	90/2	100BL 4
36	38.9	1001	1.7	112/2	100BL 4
32	43.7	1101	0.8	90/3	100BL 4
32	44.7	1150	1.5	112/2	100BL 4
28	51.2	1290	1.3	112/3	100BL 4
24	58.5	1474	1.2	112/3	100BL 4
21	67.4	1698	1.0	112/3	100BL 4
19.4	72.6	1829	1.0	112/3	100BL 4
18.0	78.5	1978	0.9	112/3	100BL 4

5.5 kW	$n_1 = 2880 \text{ min}^{-1}$ $n_1 = 1400 \text{ min}^{-1}$	112B 2 112BL 4
---------------	--	-------------------

1108	2.6	45	2.7	71/2	112B 2
960	3.0	52	1.5	63/2	112B 2
900	3.2	55	2.5	71/2	112B 2
758	3.8	66	2.4	71/2	112B 2
738	3.9	68	1.3	63/2	112B 2
670	4.3	75	2.4	71/2	112B 2
670	4.3	75	1.3	63/2	112B 2
576	5.0	87	1.3	63/2	112B 2
543	5.3	92	2.0	71/2	112B 2
538	2.6	93	1.4	71/2	112BL 4
519	2.7	96	3.4	90/2	112BL 4
438	3.2	114	1.3	71/2	112BL 4
368	3.8	135	1.3	71/2	112BL 4
333	4.2	150	3.2	90/2	112BL 4
326	4.3	153	1.3	71/2	112BL 4
326	4.3	153	0.8	63/2	112BL 4
264	5.3	189	2.8	90/2	112BL 4
264	5.3	189	1.1	71/2	112BL 4



1.7 Prestazioni motoriduttori
PMP - PCP - PMF - PCF

n_2 min ⁻¹	ir	T2 Nm	FS'	PMP - PCP PMF - PCF	
----------------------------	----	----------	-----	------------------------	--

5.5 kW	$n_1 = 2880 \text{ min}^{-1}$ $n_1 = 1400 \text{ min}^{-1}$	112B 2 112BL 4
---------------	--	-------------------

250	5.6	200	0.8	63/2	112BL 4
237	5.9	210	2.7	90/2	112BL 4
226	6.2	221	1.2	71/2	112BL 4
209	6.7	239	2.5	90/2	112BL 4
197	7.1	253	1.2	71/2	112BL 4
179	7.8	278	2.3	90/2	112BL 4
161	8.7	310	1.8	90/2	112BL 4
161	8.7	310	1.0	71/2	112BL 4
151	9.3	331	1.7	90/2	112BL 4
144	9.7	346	3.2	112/2	112BL 4
137	10.2	364	1.2	71/2	112BL 4
128	10.9	388	2.2	90/2	112BL 4
126	11.1	396	2.8	112/2	112BL 4
114	12.3	438	2.1	90/2	112BL 4
113	12.4	442	3.2	112/2	112BL 4
100	14.0	499	1.8	90/2	112BL 4
100	14.0	499	0.9	71/2	112BL 4
97	14.5	517	3.0	112/2	112BL 4
88	16.0	570	1.6	90/2	112BL 4
87	16.1	574	0.8	71/2	112BL 4
86	16.3	581	2.8	112/2	112BL 4
82	17.1	609	1.5	90/2	112BL 4
79	17.7	631	2.7	112/2	112BL 4
71	19.8	706	1.3	90/2	112BL 4
69	20.2	720	2.4	112/2	112BL 4
65	21.4	763	1.2	90/2	112BL 4
65	21.7	773	2.3	112/2	112BL 4
56	25.0	891	1.0	90/2	112BL 4
55	25.4	905	1.8	112/2	112BL 4
48	29.1	1037	1.7	112/2	112BL 4
46	30.5	1087	0.8	90/2	112BL 4
43	32.3	1151	1.5	112/2	112BL 4
36	38.9	1386	1.3	112/2	112BL 4
34	40.7	1451	1.2	112/2	112BL 4
31	44.7	1593	1.1	112/2	112BL 4
29	48.9	1743	1.0	112/2	112BL 4
24	58.5	2041	0.9	112/3	112BL 4

7.5 kW	$n_1 = 2860 \text{ min}^{-1}$ $n_1 = 1440 \text{ min}^{-1}$	112BL 2 132M 4
---------------	--	-------------------

1100	2.6	62	1.9	71/2*	112BL 2
953	3.0	71	1.1	63/2*	112BL 2
894	3.2	76	1.8	71/2*	112BL 2
753	3.8	90	1.8	71/2*	112BL 2
733	3.9	93	1.0	63/2*	112BL 2
665	4.3	102	1.8	71/2*	112BL 2
665	4.3	102	0.9	63/2*	112BL 2
572	5.0	119	0.9	63/2*	112BL 2
540	5.3	126	1.4	71/2*	112BL 2
533	2.7	128	2.6	90/2	132M 4
485	5.9	140	3.2	90/2	112BL 2
461	6.2	148	1.6	71/2*	112BL 2
461	6.2	148	0.9	63/2*	112BL 2
403	7.1	169	1.6	71/2*	112BL 2
367	7.8	186	2.8	90/2	112BL 2
343	4.2	198	2.4	90/2	132M 4

1.7 PMP - PCP - PMF - PCF
Gearmotors performances

n_2 min ⁻¹	ir	T2 Nm	FS'	PMP - PCP PMF - PCF	
----------------------------	----	----------	-----	------------------------	--

7.5 kW	$n_1 = 2860 \text{ min}^{-1}$ $n_1 = 1440 \text{ min}^{-1}$	112BL 2 132M 4
---------------	--	-------------------

272	5.3	250	2.1	90/2	132M 4
244	5.9	279	2.0	90/2	132M 4
236	6.1	288	3.3	112/2	132M 4
215	6.7	317	1.9	90/2	132M 4
212	6.8	321	3.1	112/2	132M 4
185	7.8	369	1.8	90/2	132M 4
182	7.9	373	2.8	112/2	132M 4
166	8.7	411	1.4	90/2	132M 4
162	8.9	421	2.6	112/2	132M 4
148	9.7	458	2.4	112/2	132M 4
148	9.7	458	1.8	90/2	132M 4
132	10.9	515	1.7	90/2	132M 4
130	11.1	525	2.1	112/2	132M 4
117	12.3	581	1.6	90/2	132M 4
116	12.4	586	2.4	112/2	132M 4
103	14.0	662	1.4	90/2	132M 4
99	14.5	685	2.3	112/2	132M 4
90	16.0	756	1.2	90/2	132M 4
88	16.3	770	2.1	112/2	132M 4
84	17.1	808	1.1	90/2	132M 4
81	17.7	836	2.0	112/2	132M 4
73	19.8	936	1.0	90/2	132M 4
71	20.2	955	1.8	112/2	132M 4
67	21.4	1011	0.9	90/2	132M 4
66	21.7	1025	1.7	112/2	132M 4
57	25.4	1200	1.3	112/2	132M 4
49	29.1	1375	1.3	112/2	132M 4
45	32.3	1526	1.1	112/2	132M 4
37	38.9	1838	1.0	112/2	132M 4
35	40.7	1923	0.9	112/2	132M 4
32	44.7	2112	0.8	112/2	132M 4

9.2 kW	$n_1 = 1450 \text{ min}^{-1}$	132ML 4
---------------	-------------------------------	---------

537	2.7	155	2.1	90/2	132ML 4
426	3.4	196	3.3	112/2	132ML 4
363	4.0	230	3.3	112/2	132ML 4
345	4.2	242	2.0	90/2	132ML 4
315	4.6	265	3.1	112/2	132ML 4
274	5.3	305	1.7	90/2	132ML 4
246	5.9	340	1.6	90/2	132ML 4
238	6.1	351	2.7	112/2	132ML 4
216	6.7	386	1.6	90/2	132ML 4
213	6.8	391	2.5	112/2	132ML 4
186	7.8	449	1.4	90/2	132ML 4
184	7.9	455	2.3	112/2	132ML 4
167	8.7	501	1.1	90/2	132ML 4
163	8.9	512	2.1	112/2	132ML 4
156	9.3	535	1.0	90/2	132ML 4
149	9.7	558	2.0	112/2	132ML 4
149	9.7	558	1.5	90/2	132ML 4
133	10.9	627	1.4	90/2	132ML 4
131	11.1	639	1.7	112/2	132ML 4
118	12.3	708	1.3	90/2	132ML 4
117	12.4	714	2.0	112/2	132ML 4
104	14.0	806	1.1	90/2	132ML 4

1.7 Leistungen der PMP - PCP -
PMF - PCF Getriebemotoren

n_2 min ⁻¹	ir	T2 Nm	FS'	PMP - PCP PMF - PCF	
----------------------------	----	----------	-----	------------------------	--

9.2 kW	$n_1 = 1450 \text{ min}^{-1}$	132ML 4
---------------	-------------------------------	---------

100	14.5	835	1.9	112/2	132ML 4
91	16.0	921	1.0	90/2	132ML 4
89	16.3	938	1.7	112/2	132ML 4
85	17.1	984	0.9	90/2	132ML 4
82	17.7	1019	1.7	112/2	132ML 4
72	20.2	1163	1.5	112/2	132ML 4
67	21.7	1249	1.4	112/2	132ML 4
57	25.4	1462	1.1	112/2	132ML 4
50	29.1	1675	1.0	112/2	132ML 4
45	32.3	1859	0.9	112/2	132ML 4

11 kW	$n_1 = 2940 \text{ min}^{-1}$ $n_1 = 1455 \text{ min}^{-1}$	132M 2 160M 4
--------------	--	------------------

1089	2.7	92	2.9	90/2*	132M 2
865	3.4	115	4.5	112/2	132M 2
700	4.2	143	2.7	90/2*	132M 2
555	5.3	180	2.4	90/2*	132M 2
502	2.9	199	3.0	112/2	160M 4
428	3.4	233	2.7	112/2	160M 4
364	4.0	274	2.7	112/2	160M 4
316	4.6	316	2.6	112/2	160M 4
239	6.1	418	2.3	112/2	160M 4
214	6.8	466	2.1	112/2	160M 4
184	7.9	542	1.9	112/2	160M 4
163	8.9	610	1.8	112/2	160M 4
150	9.7	665	1.7	112/2	160M 4
131	11.1	761	1.4	112/2	160M 4
117	12.4	851	1.7	112/2	160M 4
100	14.5	995	1.6	112/2	160M 4
89	16.3	1118	1.5	112/2	160M 4
82	17.7	1214	1.4	112/2	160M 4
72	20.2	1386	1.3	112/2	160M 4
67	21.7	1488	1.2	112/2	160M 4
57	25.4	1742	0.9	112/2	160M 4
50	29.1	1996	0.9	112/2	160M 4

15 kW	$n_1 = 2900 \text{ min}^{-1}$ $n_1 = 1455 \text{ min}^{-1}$	132ML 2 160L 4
--------------	--	-------------------

1074	2.7	127	2.1	90/2*	132ML 2
853	3.4	160	3.3	112/2	132ML 2
725	4.0	188	3.2	112/2	132ML 2
690	4.2	197	2.0	90/2*	132ML 2
630	4.6	216	3.1	112/2	132ML 2
547	5.3	249	1.7	90/2*	132ML 2
502	2.9	271	2.2	112/2	160L 4
428	3.4	318	2.0	112/2	160L 4
364	4.0	374	2.0	112/2	160L 4
316	4.6	430	1.9	112/2	160L 4
239	6.1	571	1.7	112/2	160L 4
214	6.8	636	1.6	112/2	160L 4



**1.7 Prestazioni motoriduttori
PMP - PCP - PMF - PCF**

n_2 min ⁻¹	ir	T2 Nm	FS'	PMP - PCP PMF - PCF	
----------------------------	----	----------	-----	------------------------	--

15 kW	$n_1 = 2900 \text{ min}^{-1}$	132ML 2
	$n_1 = 1455 \text{ min}^{-1}$	160L 4

n_2 min ⁻¹	ir	T2 Nm	FS'	PMP - PCP PMF - PCF	Model
184	7.9	739	1.4	112/2	160L 4
163	8.9	832	1.3	112/2	160L 4
150	9.7	907	1.2	112/2	160L 4
131	11.1	1038	1.1	112/2	160L 4
117	12.4	1160	1.2	112/2	160L 4
100	14.5	1356	1.1	112/2	160L 4
89	16.3	1525	1.1	112/2	160L 4
82	17.7	1655	1.0	112/2	160L 4
72	20.2	1889	0.9	112/2	160L 4
67	21.7	2030	0.9	112/2	160L 4

18.5 kW	$n_1 = 2910 \text{ min}^{-1}$	160L 2
----------------	-------------------------------	--------

n_2 min ⁻¹	ir	T2 Nm	FS'	PMP - PCP PMF - PCF	Model
1003	2.9	167	2.9	112/2*	160L 2
856	3.4	196	2.7	112/2*	160L 2
728	4.0	231	2.6	112/2*	160L 2
633	4.6	265	2.5	112/2*	160L 2
477	6.1	352	2.2	112/2*	160L 2
428	6.8	392	2.1	112/2*	160L 2
368	7.9	456	1.9	112/2*	160L 2
327	8.9	513	1.7	112/2*	160L 2
300	9.7	559	1.6	112/2*	160L 2
262	11.1	640	1.5	112/2*	160L 2
235	12.4	715	1.6	112/2*	160L 2
201	14.5	836	1.5	112/2*	160L 2
179	16.3	940	1.4	112/2*	160L 2
164	17.7	1021	1.4	112/2*	160L 2
144	20.2	1165	1.2	112/2*	160L 2
134	21.7	1252	1.2	112/2*	160L 2
115	25.4	1465	1.0	112/2*	160L 2
100	29.1	1678	0.9	112/2*	160L 2

**1.7 PMP - PCP - PMF - PCF
Gearmotors performances**

n_2 min ⁻¹	ir	T2 Nm	FS'	PMP - PCP PMF - PCF	
----------------------------	----	----------	-----	------------------------	--

**1.7 Leistungen der PMP - PCP -
PMF - PCF Getriebemotoren**

n_2 min ⁻¹	ir	T2 Nm	FS'	PMP - PCP PMF - PCF	
----------------------------	----	----------	-----	------------------------	--

N.B.
Tutte le potenze indicate si riferiscono alla potenza meccanica dei riduttori.
Per i riduttori contrassegnati con (*) è opportuno effettuare la verifica della potenza limite termico secondo le indicazioni riportate nel par. A-1.7.

NOTE.
The indicated power is based on the mechanical capacities of the gearboxes. For the gearboxes marked with () it is also necessary to obey the thermal capacity like shown on chapter A-1.7.*

HINWEIS.
Die Leistungsangaben beziehen sich auf die mechanische Belasbarkeit der Getriebe. Bei den mit (*) gekennzeichneten Getrieben ist außerdem die thermische Leistungsgrenze zu beachten (s. Kap. A-1.7).





1.8 Dimensioni

1.8 Dimensions

1.8 Abmessungen

PMP

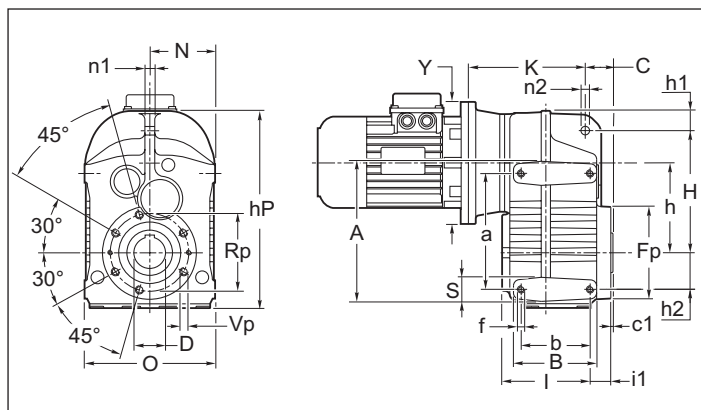

PMF

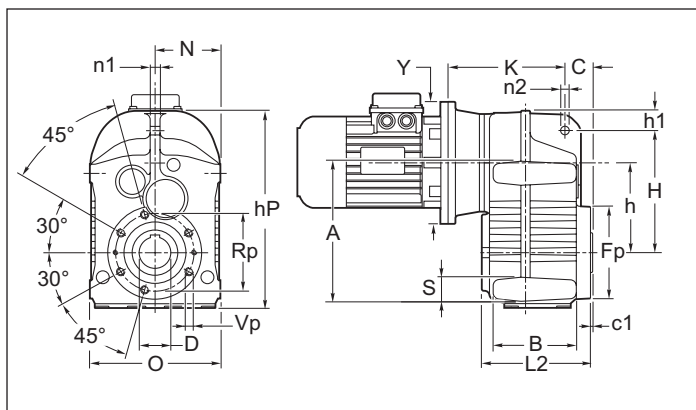

PMP F1 - F2

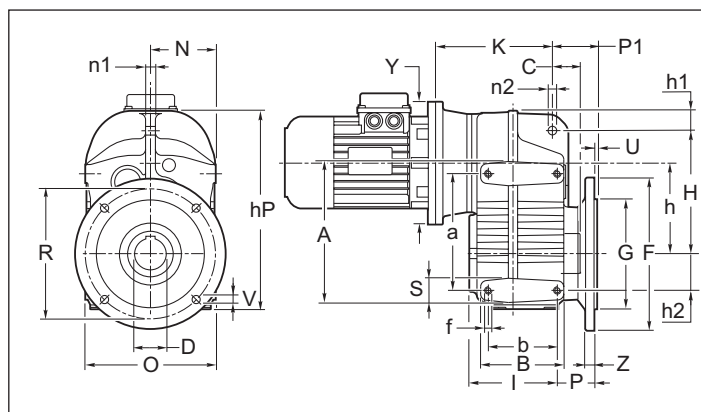

PMF F1 - F2

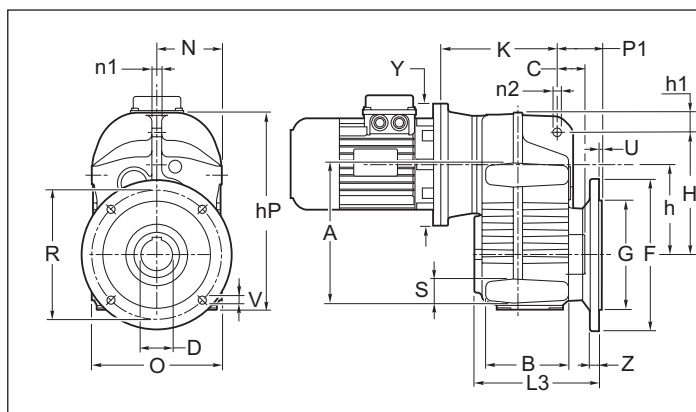

PMP P

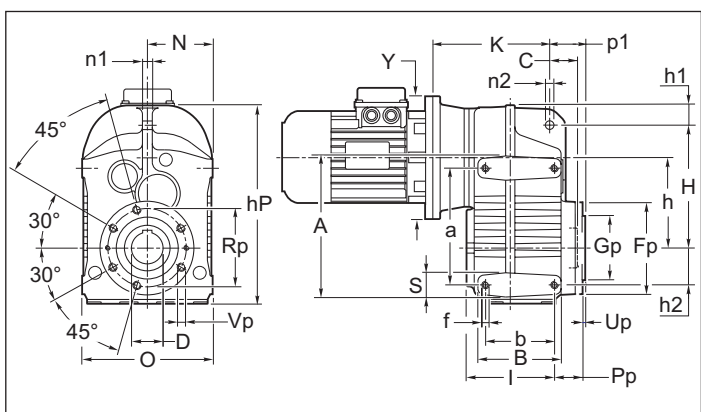

PMF P

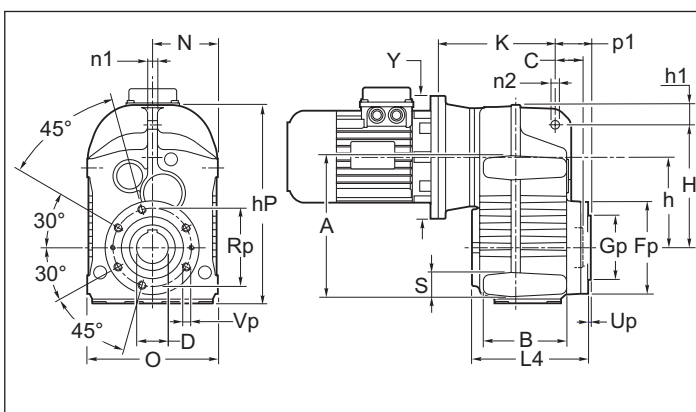

Download 2D/3D





Tab. 4.6

P.P P.F	a	A	b	B	C	c1	D H7	f	h	hP	H	h1	h2	I	I1	L2	L3	L4	N	n1	n2
63	115	135	77	95	31.5	2.5	30 (25) (28)	N° 8 M8x12	103.5	240	152	23.5	31	96.5	20	116.5	143	128	P.F 84.5	12	14
																			P.P 82.5		
71	145	170	93	120	35	3	35 (30) (32)	N° 8 M10x15	117	268	165	26	43	119	28	147	175	158	P.F 92	12	14
																			P.P 90		
90	190	220	112	135	45	3.5	40 (42) (45) (48)	N° 8 M12x17	147	324	200	33	60	143	33.5	176.5	203.5	188.5	P.F 109	16	14
																			P.P 106		
112	240	280	140	166	50	4	50 (55)	N° 8 M16x23	184	400	255	35.5	70	172.5	32.5	205	246	219	P.F 138	20	22
																			P.P 135		

P.P P.F	S	Fp	Gp	O	p1	P1	Pp	Rp	Up	Vp	F	G g6	P	R	U	V	Z	
63	20	105	80	P.F 169	43.5	59	31.5	90	3	N°6 M6x12	F1	160	110	46.5	130	3.5	N°4 φ 9	10
				F2							—	—	—		—			
71	25	120	80	P.F 184	46	63.5	39	100	3	N°6 M8x14	F1	200	130	56	165	3.5	N°4 φ 11	12
				F2							160	110	130		3.5	N°4 φ 9.5	10	
90	30	150	105	P.F 218	57	72	45.5	125	3.5	N°6 M12x18	F1	250	180	60.5	215	4	N°4 φ 13.5	15
				F2							—	—	—		—			
112	40	175	125	P.F 276	63	91	46.5	150	3.5	N°6 M14x21	F1	300	230	73.5	265	4	N°4 φ 13.5	16
				F2							—	—	—		—			

Tab. 4.7

PM. 2 stadi	IEC	63		71		90		112	
		Y	K (PM.)	Y	K (PM.)	Y	K (PM.)	Y	K (PM.)
	B5		140	120 140*	160	159	200	205	250
		160	120 140*	200	159	250	205	300	255
		200	140	250	169	300	205	350	255
		250	150	—	—	—	—	—	—
B14		120	140	120	159	200	205	—	—
		140	140	140	159	—	—	—	—
		160	150	160	169	—	—	—	—

PM. 3 stadi	IEC	63		71		90		112	
		Y	K (PM.)	Y	K (PM.)	Y	K (PM.)	Y	K (PM.)
	B5		140	125	140	153	160	175	200
		160	129	160	153 173*	200	190	250	230
		200	153	200	173	250	200	—	—
B14		120	153	120	173	120	190	—	—
		—	—	140	173	140	190	—	—
		—	—	—	—	160	200	—	—

* Con calettatore in posizione standard.

* With shrink disc in standard positions.

* Mit Schrumpfscheibe in Standardposition.



1.8 Dimensioni

1.8 Dimensions

1.8 Abmessungen

PCP

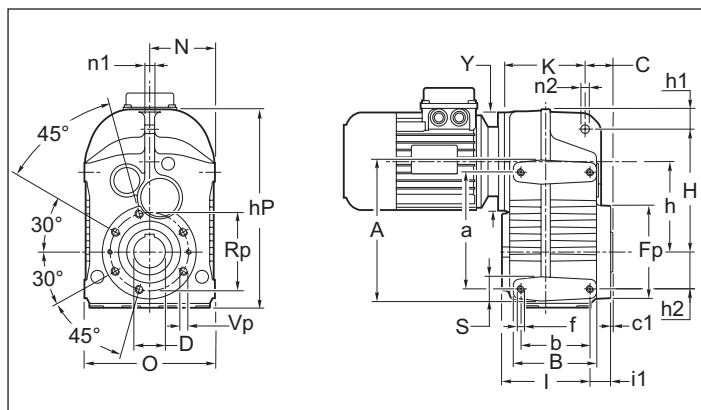

PCF

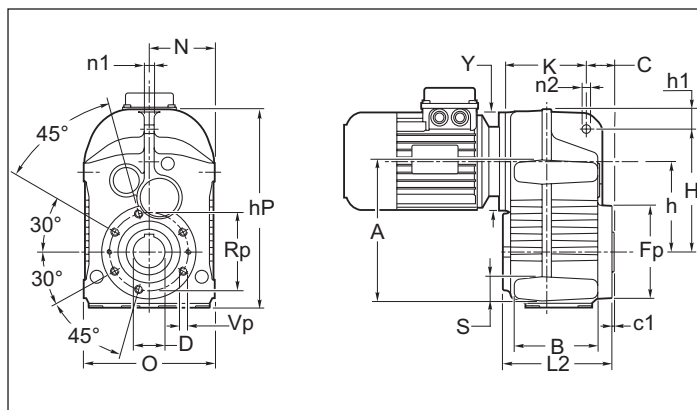

PCP F1 - F2

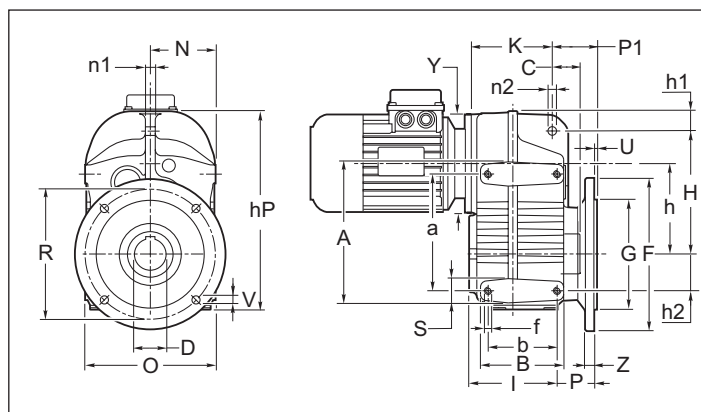

PCF F1 - F2

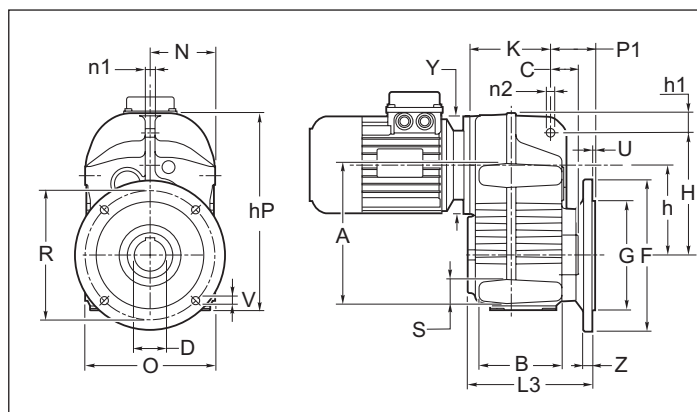

PCP P

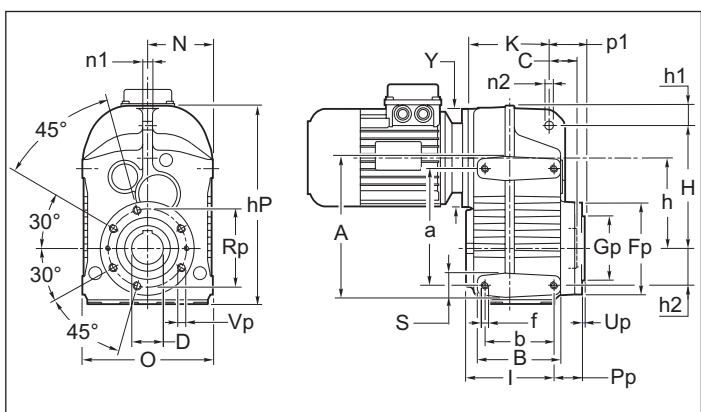

PCF P

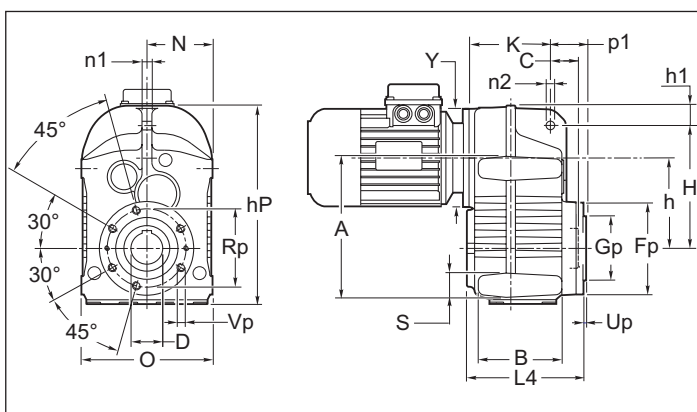



Tab. 4.8

P.P P.F	a	A	b	B	C	c1	D H7	f	h	hP	H	h1	h2	I	I1	L2	L3	L4	N	n1	n2
63	115	135	77	95	31.5	2.5	30 (25) (28)	N° 8 M8x12	103.5	240	152	23.5	31	96.5	20	116.5	143	128	P.F 84.5	12	14
																			P.P 82.5		
71	145	170	93	120	35	3	35 (30) (32)	N° 8 M10x15	117	268	165	26	43	119	28	147	175	158	P.F 92	12	14
																			P.P 90		
90	190	220	112	135	45	3.5	40 (42) (45) (48)	N° 8 M12x17	147	324	200	33	60	143	33.5	176.5	203.5	188.5	P.F 109	16	14
																			P.P 106		
112	240	280	140	166	50	4	50 (55)	N° 8 M16x23	184	400	255	35.5	70	172.5	32.5	205	246	219	P.F 138	20	22
																			P.P 135		

P.P P.F	S	Fp	Gp	O	p1	P1	Pp	Rp	Up	Vp	F	G g6	P	R	U	V	Z	
63	20	105	80	P.F 169	43.5	59	31.5	90	3	N°6 M6x12	F1	160	110	46.5	130	3.5	N°4 φ 9	10
				F2							—	—	—		—			
71	25	120	80	P.F 184	46	63.5	39	100	3	N°6 M8x14	F1	200	130	56	165	3.5	N°4 φ 11	12
				F2							160	110	130		3.5	N°4 φ 9.5	10	
90	30	150	105	P.F 218	57	72	45.5	125	3.5	N°6 M12x18	F1	250	180	60.5	215	4	N°4 φ 13.5	15
				F2							—	—	—		—			
112	40	175	125	P.F 276	63	91	46.5	150	3.5	N°6 M14x21	F1	300	230	73.5	265	4	N°4 φ 13.5	16
				F2							—	—	—		—			

Tab. 4.9

PC. 2 stadi	63		71		90		112	
	Y	K (PC.)	Y	K (PC.)	Y	K (PC.)	Y	K (PC.)
	140	81	140	114	160	131	200	163

PC. 3 stadi	63		71		90		112	
	Y	K (PC.)	Y	K (PC.)	Y	K (PC.)	Y	K (PC.)
	140	98	140	114	160	131	200	163



1.8 Dimensioni

1.8 Dimensions

1.8 Abmessungen

PRP

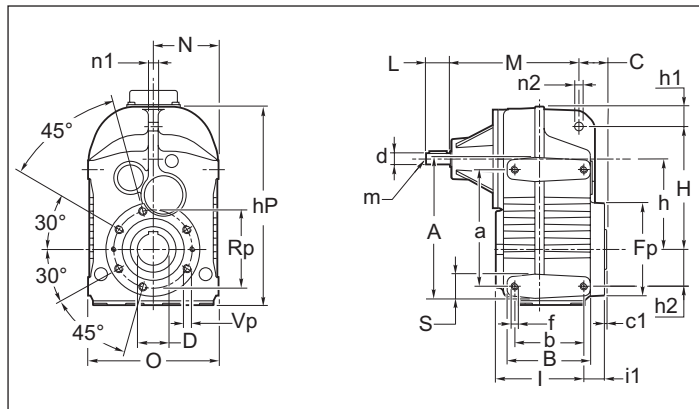

PRF

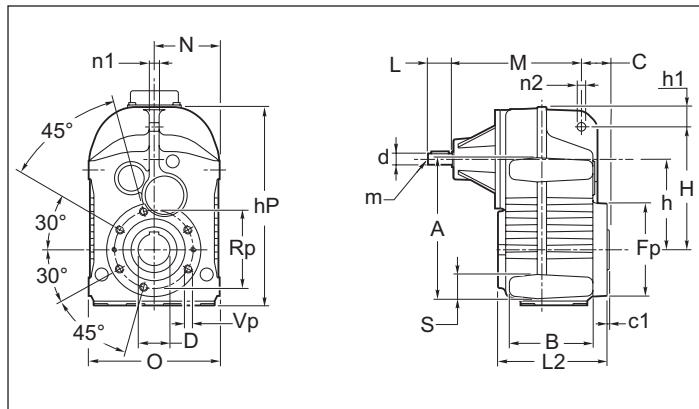

PRP F1 - F2

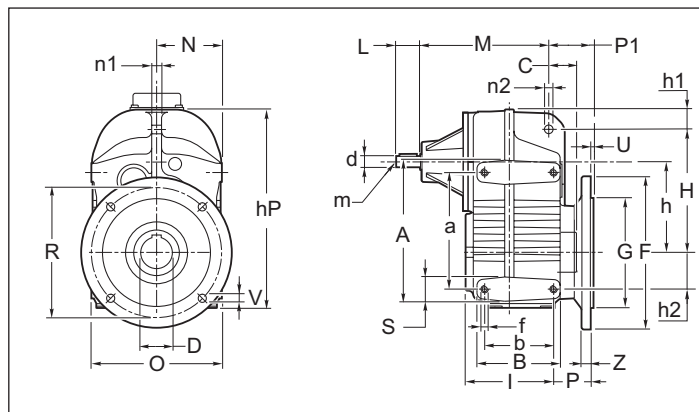

PRF F1 - F2

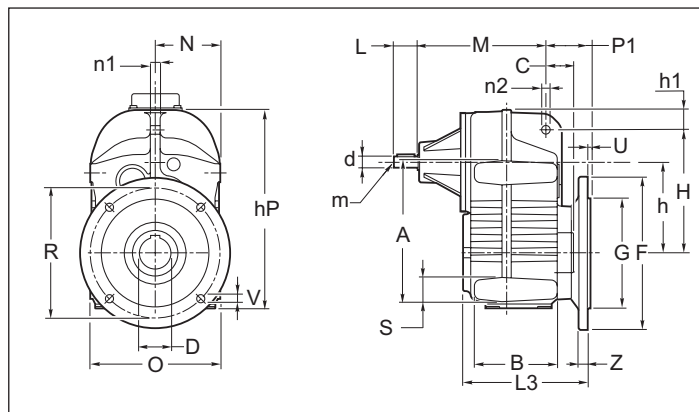

PRP P

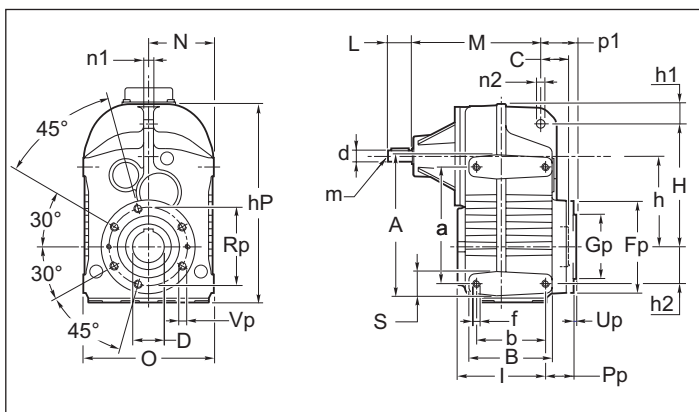

PRF P

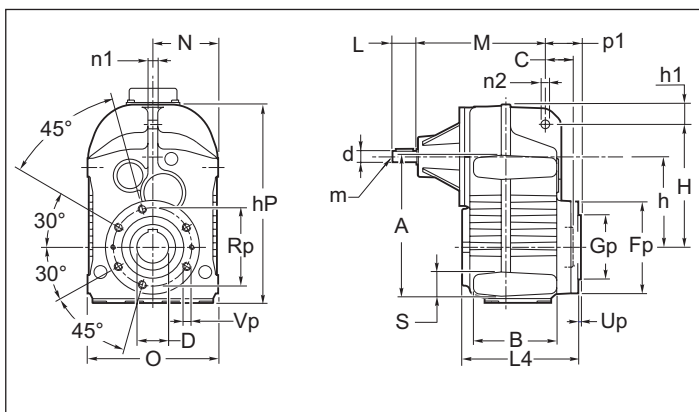



Tab. 4.10

P.P P.F	a	A	b	B	C	c1	d j6	D H7	f	h	hP	H	h1	h2	I	I1	L	L2	L3	L4	m	M	N
63	115	135	77	95	31.5	2,5	16	30 (25) (28)	N° 8 M8x12	103.5	240	152	23.5	31	96.5	20	40	116.5	143	128	M6	148.5 2 st.	P.F 84.5
																						136.5 3 st.	P.P 82.5
71	145	170	93	120	35	3	16	35 (30) (32)	N° 8 M10x15	117	268	165	26	43	119	28	40	147	175	158	M6	163.5 2 st.	P.F 92
																						182 3 st.	P.P 90
90	190	220	112	135	45	3.5	19	40 (42) (45) (48)	N° 8 M12x17	147	324	200	33	60	143	33.5	40	176.5	203.5	188.5	M6	187 2 st.	P.F 109
																						209 3 st.	P.P 106
112	240	280	140	166	50	4	24	50 (55)	N° 8 M16x23	184	400	255	35.5	70	172.5	32.5	50	205	246	219	M8	223.5 2 s	P.F 138
																						t. 239 3 st.	P.P 135

P.P P.F	n1	n2	O	p1	P1	S	Fp	Gp	Pp	Rp	Up	Vp		F	G g6	P	R	U	V	Z
63	12	14	P.F 169	43.5	59	20	105	80	31.5	90	3	N°6 M6x12	F1	160	110	46.5	130	3.5	N°4 φ 9	10
			P.P 165										F2	—	—		—	—		
71	12	14	P.F 184	46	63.5	25	120	80	39	100	3	N°6 M8x14	F1	200	130	56	165	3.5	N°4 φ 11	12
			P.P 180										F2	160	110		130	3.5		N°4 φ 9.5
90	16	14	P.F 218	57	72	30	150	105	45.5	125	3.5	N°6 M12x18	F1	250	180	60.5	215	4	N°4 φ 13.5	15
			P.P 212										F2	—	—		—	—		—
112	20	22	P.F 276	63	91	40	175	125	46.5	150	3.5	N°6 M14x21	F1	300	230	73.5	265	4	N°4 φ 13.5	16
			P.P 270										F2	—	—		—	—		—



PARTICOLARE DEI FORI “t” NELLA FLANGIA P

Per il fissaggio al riduttore con i fori “Vp” considerare la lunghezza delle viti adeguate, e che la quota “yt” non è filettata (vedi disegno).

DETAIL “t” OF THE FLANGE P HOLES

When P-flange is used please consider that the threads “Vp” are in gearcase and that Distance “yt” does not have a thread (see drawing).

DETAIL “t” BEI VERWENDUNG DES P-FLANSCHES

Bei Verwendung des P-Flansches ist zu beachten, daß sich die Gewinde im Getriebegehäuse befinden und daß Maß “yt” kein Gewinde besitzt. Details siehe Zeichnung.

Fig. 4.11

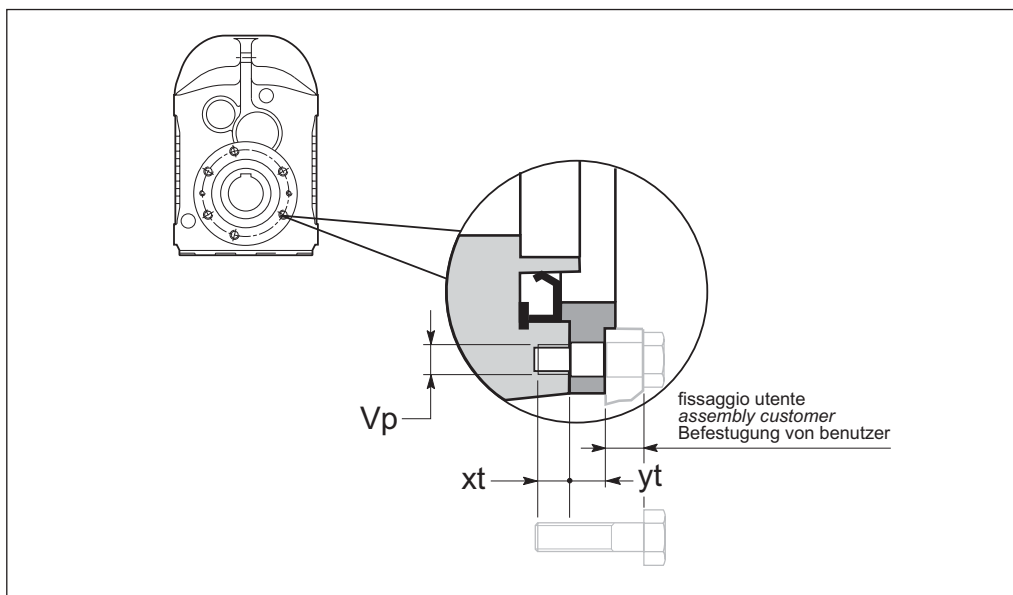

Tab. 4.12

P.P - P.F	Vp	xt	yt
63	N°6 M6	12	11,5
71	N°6 M8	14	11
90	N°6 M12	18	12
112	N°6 M14	21	14

N.B.
xt = profondità della parte filettata, utile per il fissaggio delle viti.

NOTE.
xt = thread length.

HINWEIS.
xt = Gewindetiefe.



ALBERI LENTI

OUTPUT SHAFT

ABTRIEBSWELLEN

Estremità d'albero uscita

Output shaft end

Ende der Abtriebswelle

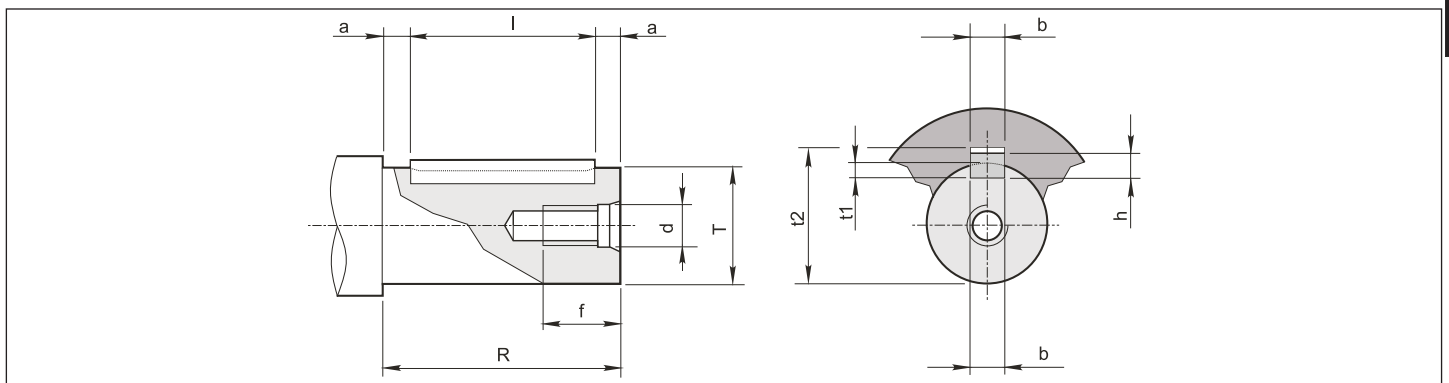
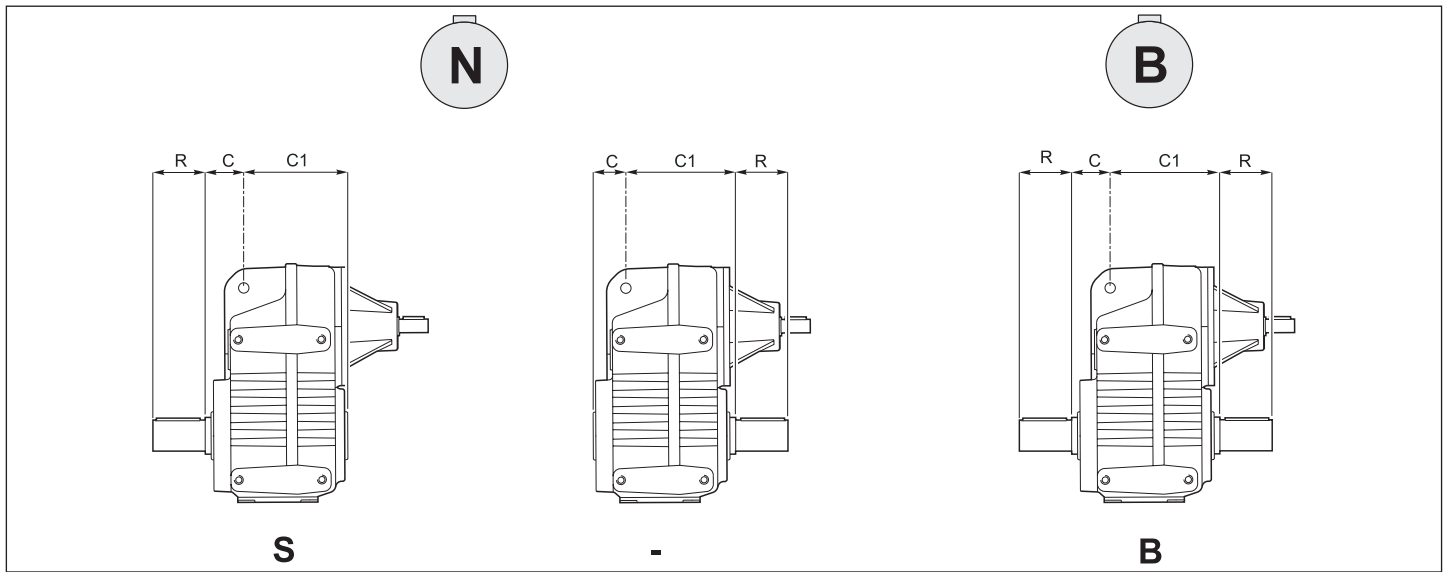

	Ø Albero Ø Shaft Ø Welle			Foro fil. testa Tapped hole Gewindebohrung Kopfi		Cava Keyway Nut			Estremità d'albero Shaft end Wellenende		Linguetta Key Federkeil
	T	C	C1	d	f	b	t1	t2	R	a	bxhxl
63	30 g6	31.5	88.5	M 10	25	8	4	33.3	60	5	8X7X50
71	35 g6	35	115	M 10	25	10	5	38.3	70	5	10x8x60
90	40 g6	45	135	M 10	25	12	5	43.3	80	5	12x8x70
112	50 g6	50	160	M 12	32	14	5.5	53.8	100	5	14x9x90



ALBERI LENTI

Albero lento cavo

OUTPUT SHAFT

Output shaft with keyway

ABTRIEBSWELLEN

Abtriebswelle mit passfedernut

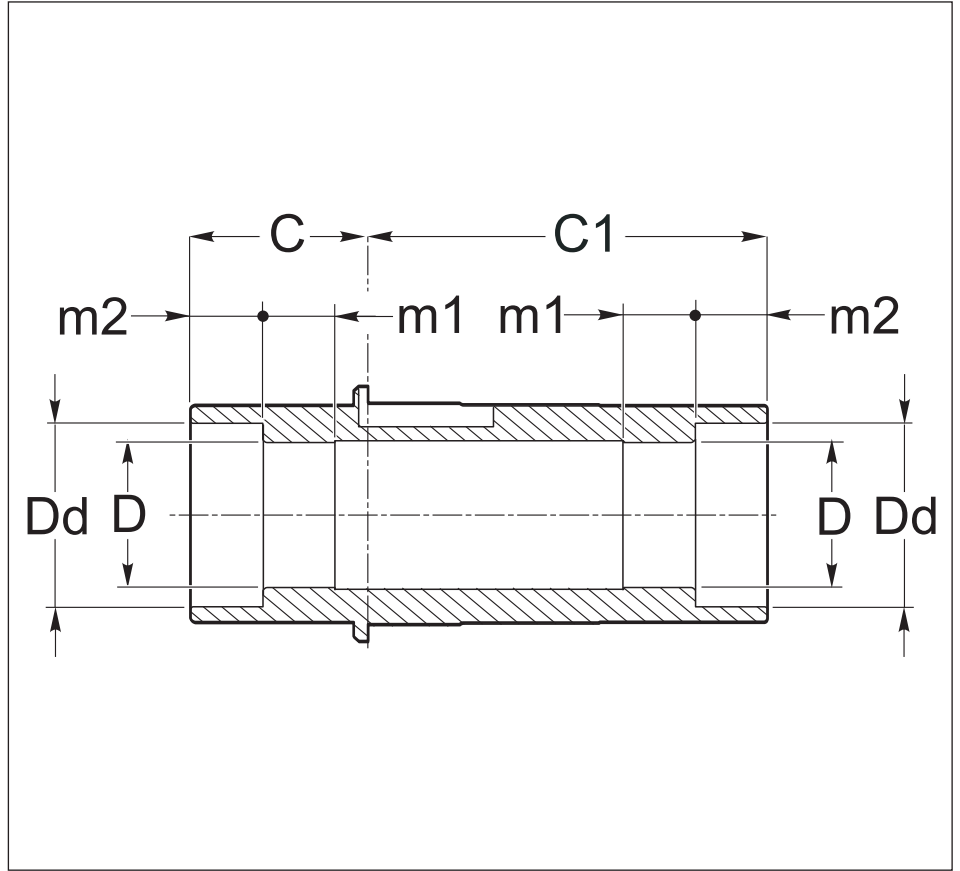
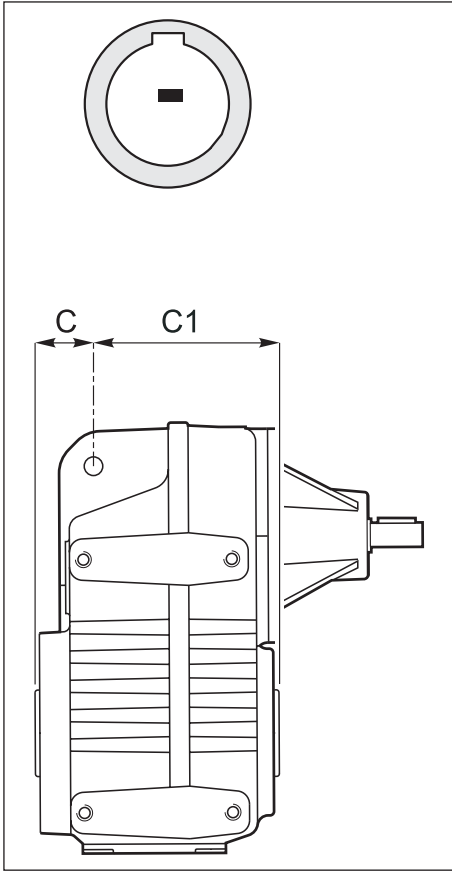

	63	71	90	112
C	31.5	35	45	50
C1	88.5	115	135	160
D	30	35	40	50
H7	(25) (28)	(30) (32)	(42) (45) (48)	(55)
m1	15	30	35	35
m2	15	15	20	25
Dd	38	43	55	61

Perno macchina / Customer shaft / Maschinachse

	d1 h6	m3	Lm	m	H	L min	P	R	Ra	Rb
63	30 (25) (28)	20	25 (25) (25)	M 10 (M 8) (M 10)	88	50	29.8 (24.8) (27.8)	36		
71	35 (30) (32)	35	25	M 10	118	60	34.8 (29.8) (31.8)	42.5		
90	40 (42) (45) (48)	40	25	M 10	138	90	39.8 (41.8) (44.8) (47.8)	54.5		
112	50 (55)	35	32	M 12	158	110	49.8 (54.8)	60		

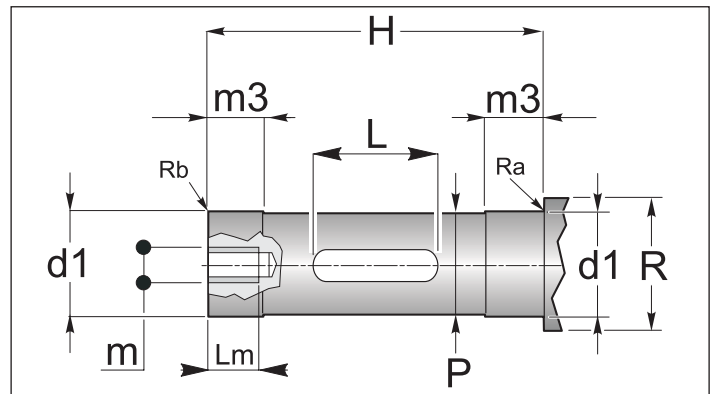



ALBERI LENTI

Estremità albero lento scanalato senza flangia brocciata

OUTPUT SHAFT

Splined output shaft without broached flange

ABTRIEBSWELLEN

Abtriebswelle mit Keilende ohne geräumtem Flansch

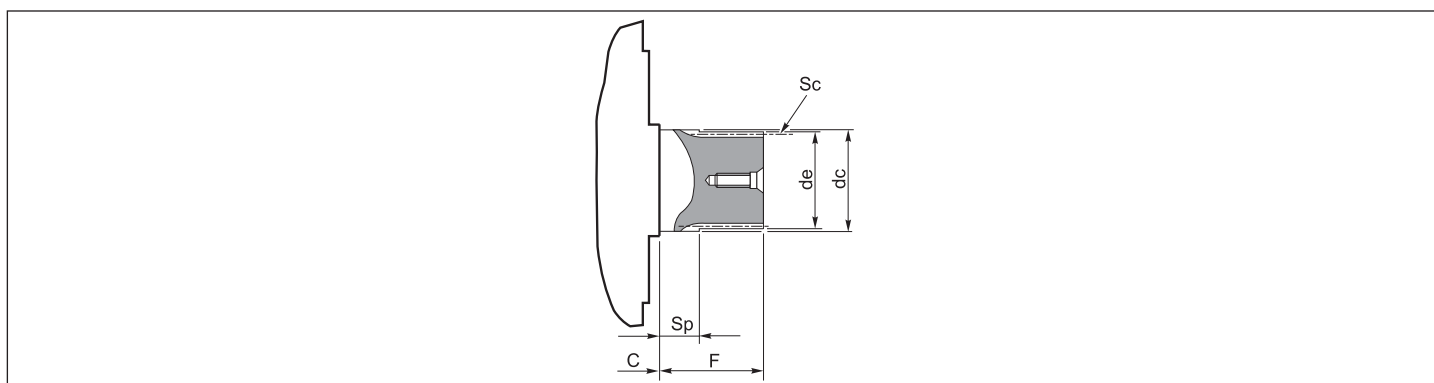
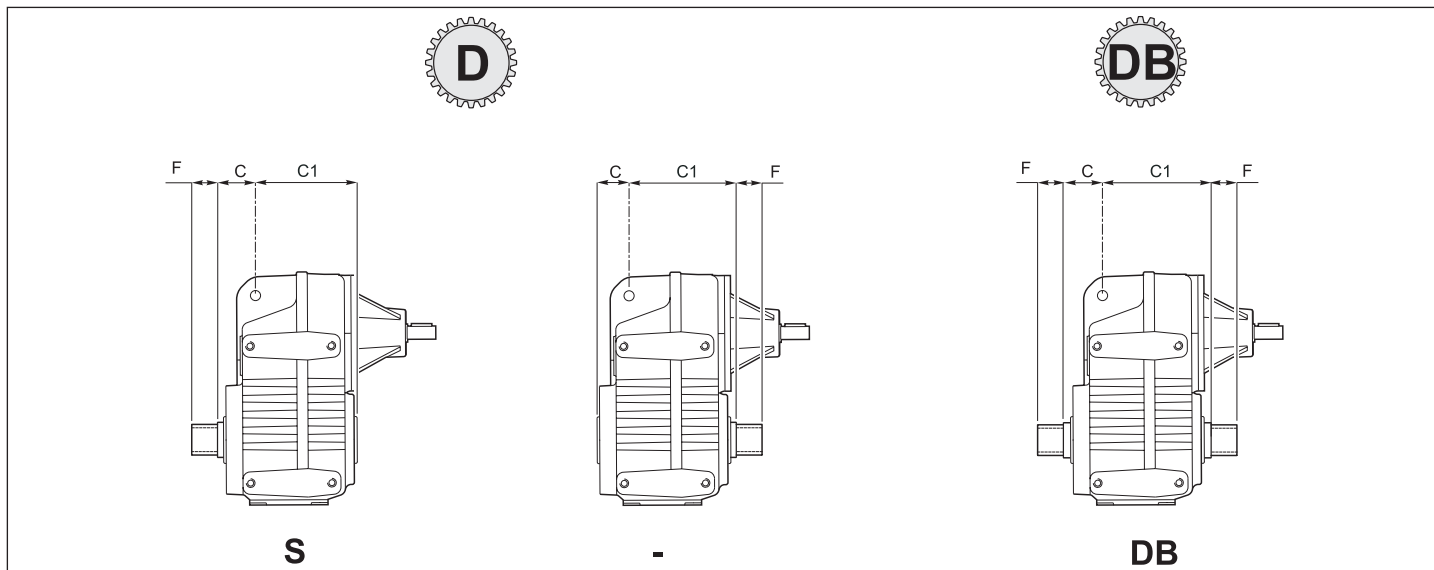

	C	C1	de (h10)	F	Profilo scanalato / Splined profile / Keilprofil					
					Sc	Z	mn	α	dc (f7)	Sp
63	31.5	88.5	*		28 x 25 DIN 5482					
71	35	115			35 x 31 DIN 5482					
90	45	135			40 x 36 DIN 5482					
112	50	160			50 x 45 DIN 5482					

*Contattare il ns. servizio tecnico / Contact our technical dept / Wenden Sie sich an unseren technischen Service

ALBERI LENTI

Albero lento cavo scanalato

OUTPUT SHAFT

Splined hollow shaft

ABTRIEBSWELLEN

Verzahnte Hohlwelle

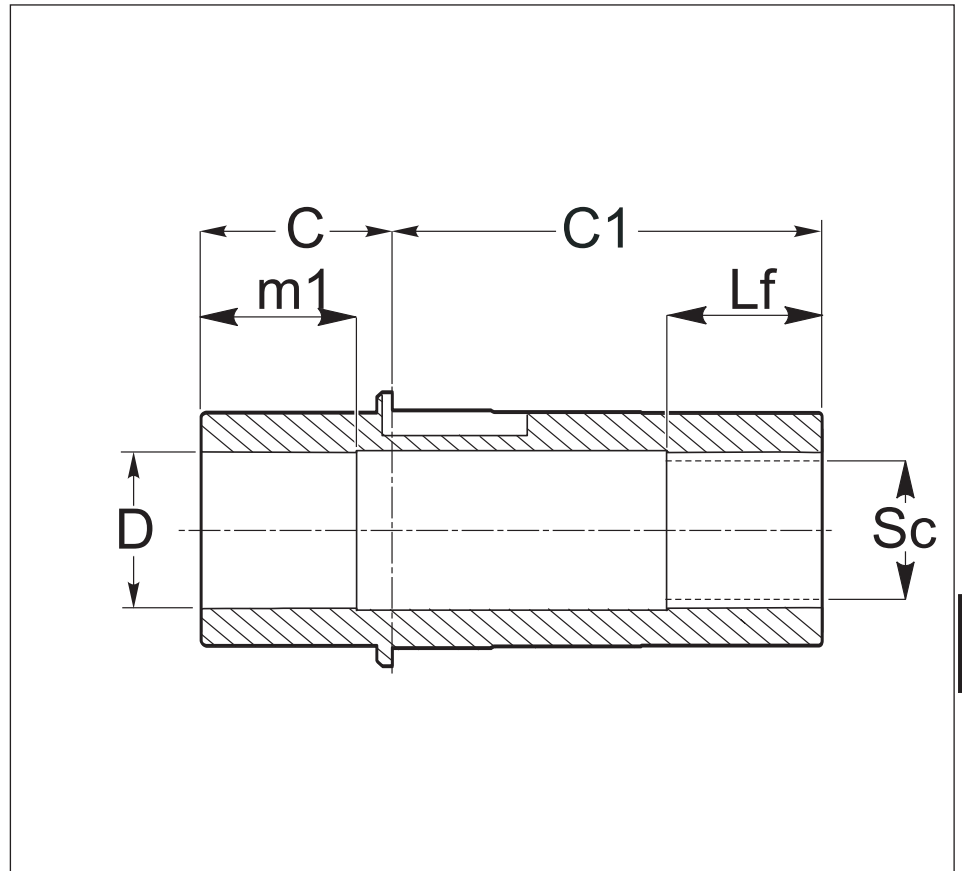
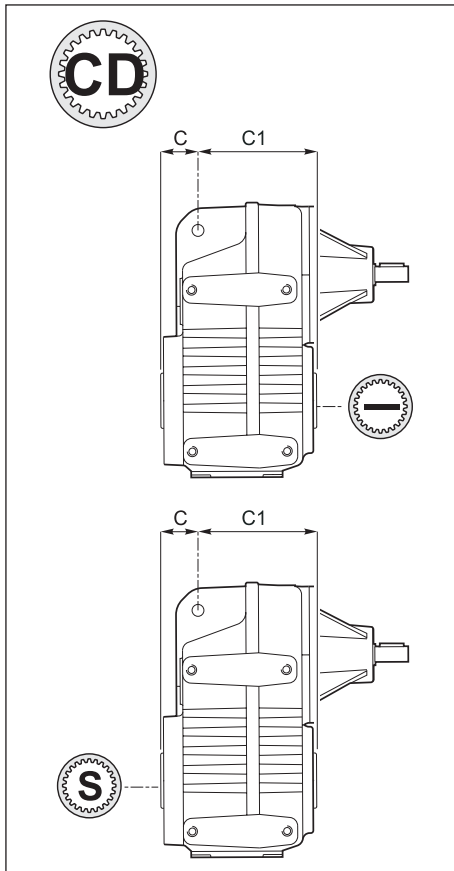

	63	71	90	112
C	31.5	35	45	50
C1	88.5	115	135	160
D	*	37	45	55
H7				
m1	*	40	55	60
Lf	*	45	55	65
Sc	28 x 25 DIN 5482	35 x 31 DIN 5482	40 x 36 DIN 5482	50 x 45 DIN 5482

Perno macchina / Customer shaft / Maschinachse

	d1 h6	m3	H	P	R	Ra	Rb	Sc	F	Lf	Lm	m
63												
71				*						*		
90												
112												

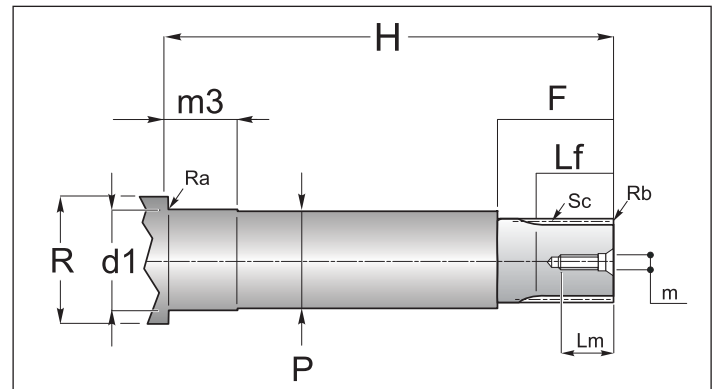

*Contattare il ns. servizio tecnico / Contact our technical dept / Wenden Sie sich an unseren technischen Service



ALBERI LENTI

OUTPUT SHAFT

ABTRIEBSWELLEN

Estremità scanalata albero lento flangia brocciata

Splined output shaft and broached flange

Abtriebswelle mit Keilende und geräumtem Flansch

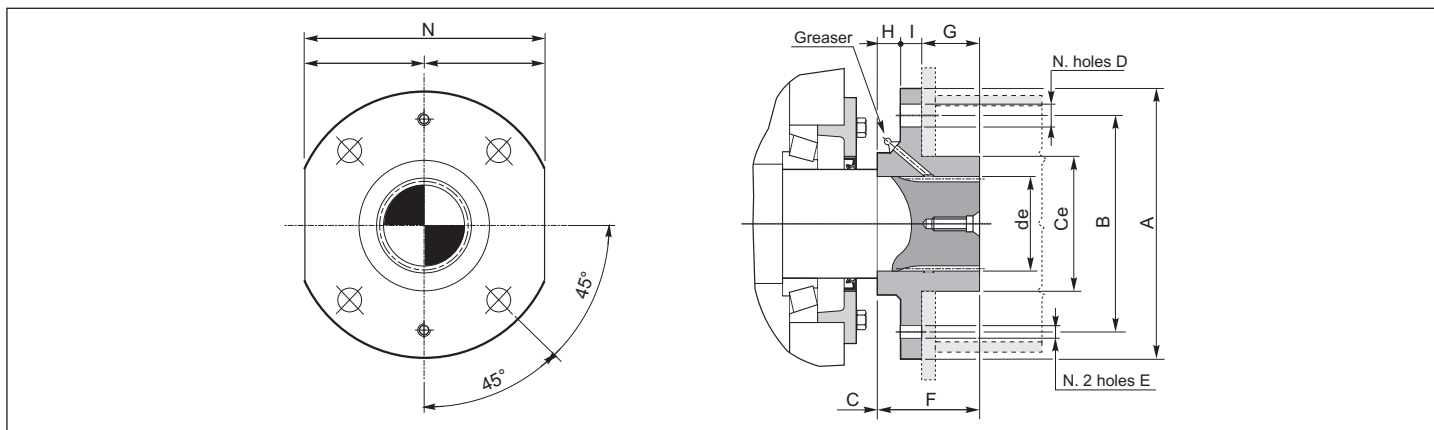
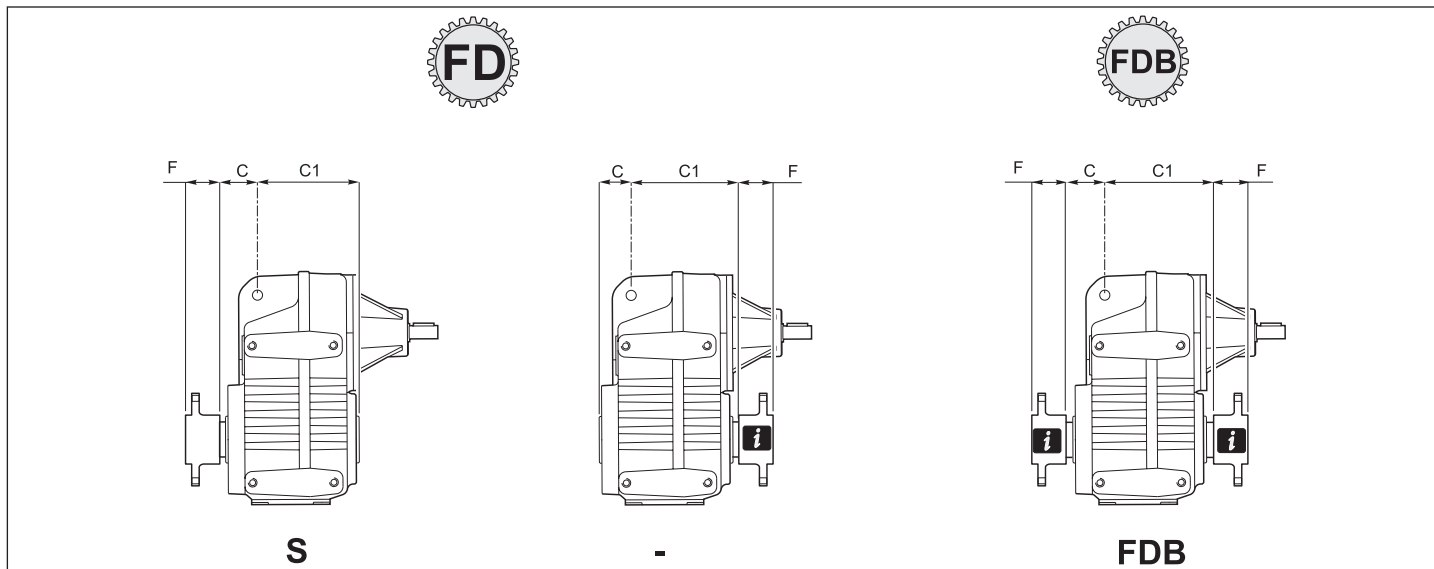

Dimensioni generali / General dimensions / Allgemeine Abmessungen														
	de	∅ A	∅ B	∅ C	∅ C1	∅ Ce f8	N° Fori holes Anzahl der Bohrungen	∅ D	E	F	G	H	I	N h9
63				31.5	88.5									
71		*		35	115					*				
90				45	135									
112				50	160									

Da verificare la compatibilità dimensionale con la versione richiesta/

*Contattare il ns. servizio tecnico / Contact our technical dept / Wenden Sie sich an unseren technischen Service



1.9 Accessori

ANTIVIBRANTE VKL

Per riduttori e motoriduttori pendolari.

Fig. 4.15

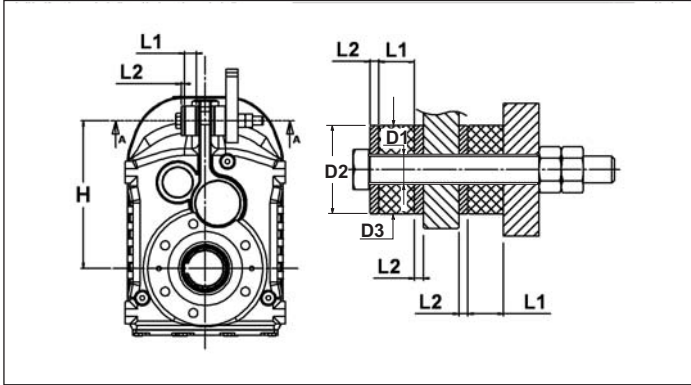

1.9 Accessories

RUBBER BUFFER VKL

For shaft mounted gearboxes and geared motors.

Tab. 4.15

P.P - P.F	D1	D2	D3	L1	L2	H
63	12.5	40	40	16	4	152
71	12.5	40	40	16	4	165
90	12.5	40	40	16	4	200
112	21	60	60	22	8	255

1.9 Zubehör

GUMMIHÜLSE VKL

Für aufsteckgetriebe und aufsteckgetriebe-motoren.

ALBERO LENTO SPORGENTE

Tutti i riduttori sono forniti con albero lento cavo. A richiesta, possono essere forniti kit di montaggio per alberi sporgenti comprensivi di linguette, rondelle e viti di fissaggio. Le dimensioni delle linguette sono conformi alle norme UNI 6604-69.

SINGLE OUTPUT SHAFTS

All gearboxes are supplied with hollow output shaft. On request there are available also assembly kits including output shafts, keys, washers and assembly screws. The dimensions of the keys are conform with UNI 6604-69.

EINSEITIGE ABTRIEBSWELLEN

Alle Getriebe werden mit Abtriebshohlwelle geliefert. Auf Anfrage sind auch Montagekits inklusive Abtriebswellen, Paßfedern, Unterlegscheiben und Montageschrauben erhältlich. Die Abmessungen der Paßfedern sind konform mit der UNI

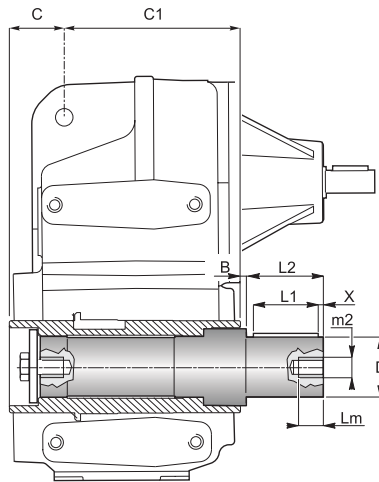

	B	C	C1	D g6	m ₂	L ₁	L ₂	L _m	X
63*	1	31.5	88.5	30	M10	50	60	25	5
71*	1	35	115	35	M10	60	70	25	5
90*	1	45	135	40	M10	70	80	25	5
112*	1	50	160	50	M12	90	100	32	5

* ATTENZIONE

L'albero lento sporgente è fornito per essere installato sulla versione del riduttore con albero **CAVO** con diametro **STANDARD**.

*ATTENTION

The output shaft is available only for standard hollow shaft diameter.

Achtung:

Die Einseitige Abtriebswelle wird fuer die Montage bei Getrieben mit Standart Hohlwelle geliefert.



1.10 Linguette

1.10 Keys

1.10 Paßfedern

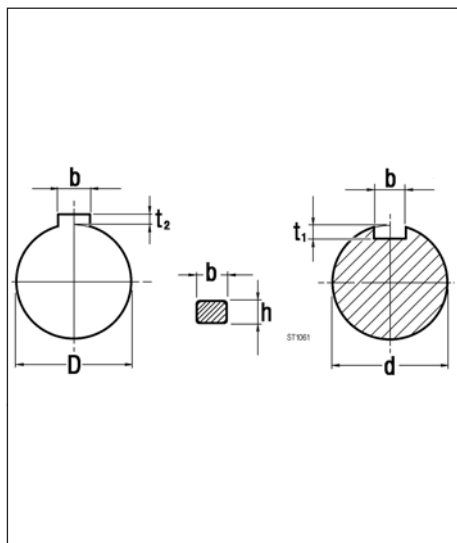

Albero entrata
Input shaft
Antriebswelle

Albero uscita
Output shaft
Abtriebswelle

Tab. 4.17

d	bxh	t1	
16	5x5	3	0/ +0.1
19	6x6	3.5	
24	8x7	4	0/ +0.2

D	bxh	t2	
25	8x7	3.3	0/ +0.2
28	8x7	3.3	
30	8x7	3.3	
32	10x8	3.3	
35	10x8	3.3	
40	12x8	3.3	
42	12x8	3.3	
45	14x9	3.8	
48	14x9	3.8	
50	14x9	3.8	
55	16x10	4.3	